

34
P-23

**THE INFLUENCE OF SWIRL BRAKES AND A TIP DISCHARGE ORIFICE ON
THE ROTORDYNAMIC FORCES GENERATED BY DISCHARGE-TO-SUCTION
LEAKAGE FLOWS IN SHROUDED CENTRIFUGAL PUMPS**

J. M. Sivo, A. J. Acosta, C. E. Brennen, T. K. Caughey

California Institute of Technology
Division of Engineering and Applied Science
Pasadena, California 91125

ABSTRACT

Recent experiments conducted in the Rotor Force Test Facility at the California Institute of Technology have examined the effects of a tip leakage restriction and swirl brakes on the rotordynamic forces due to leakage flows on an impeller undergoing a prescribed circular whirl. The experiments simulate the leakage flow conditions and geometry of the Alternate Turbopump Design (ATD) of the Space Shuttle High Pressure Oxygen Turbopump and are critical to evaluating the pump's rotordynamic instability problems.

Previous experimental and analytical results have shown that discharge-to-suction leakage flows in the annulus of a shrouded centrifugal pump contribute substantially to the fluid induced rotordynamic forces. Also, previous experiments have shown that leakage inlet (pump discharge) swirl can increase the cross-coupled stiffness coefficient and hence increase the range of positive whirl for which the tangential force is destabilizing. In recent experimental work, the present authors demonstrated that when the swirl velocity within the leakage path is reduced by the introduction of ribs or swirl brakes, then a substantial decrease in both the destabilizing normal and tangential forces could be achieved.

Motivation for the present research is that previous experiments have shown that restrictions such as wear rings or orifices at pump inlets affect the leakage forces. Recent pump designs such as the Space Shuttle Alternate Turbopump Design (ATD) utilize tip orifices at discharge for the purpose of establishing axial thrust balance. The ATD has experienced rotordynamic instability problems and one may surmise that these tip discharge orifices may also have an important effect on the normal and tangential forces in the plane of impeller rotation. The present study determines if such tip leakage restrictions contribute to undesirable rotordynamic forces.

Additional motivation for the present study is that the widening of the leakage path annular clearance and the installation of swirl brakes in the ATD has been proposed to solve its instability problems. The present study assesses the effect of such a design modification on the rotordynamic forces.

The experimental apparatus consists of a solid or dummy impeller, a housing instrumented for pressure measurements, a rotating dynamometer and an eccentric whirl mechanism. The solid impeller is used so that leakage flow contributions to the forces are measured, but the main throughflow contributions are not experienced. The inner surface of the housing has been modified to accommodate meridional ribs or swirl brakes within the leakage annulus. In addition, the housing has been modified to accommodate a discharge orifice that qualitatively simulates one side of the balance piston orifice of the Space Shuttle ATD.

Results indicate the detrimental effects of a discharge orifice and the beneficial effects of brakes. Plots of the tangential and normal forces versus whirl ratio show a substantial increase in these forces along with destabilizing resonances at some positive whirl ratios when a discharge orifice is added. When brakes are added, some of the detrimental effects of the orifice are reduced. For the tangential force, a plot versus whirl ratio shows a significant reduction and a destabilizing resonance appears to be eliminated. For the normal force, although the overall force is not reduced, again a destabilizing resonance appears to be eliminated.

**THE INFLUENCE OF SWIRL BRAKES
AND A TIP DISCHARGE ORIFICE ON
THE ROTORDYNAMIC FORCES GENERATED BY
DISCHARGE-TO-SUCTION LEAKAGE FLOWS
IN SHROUDED CENTRIFUGAL PUMPS**

Joseph M. Sivo

**California Institute of Technology
Division of Engineering and Applied Science
Pasadena, California 91125**

4/20/93

A. J. Acosta

C. E. Brennen

T. K. Caughey

OUTLINE

- Background
- Rotordynamic Forces and Coefficients
- Test Apparatus
- Phase 1 Tests
 - Effect of Swirl Brakes
- Phase 2 Tests
 - Effect of Tip Discharge Orifice
 - Effect of Brakes with Tip Discharge Orifice
- Conclusions
- Future Work

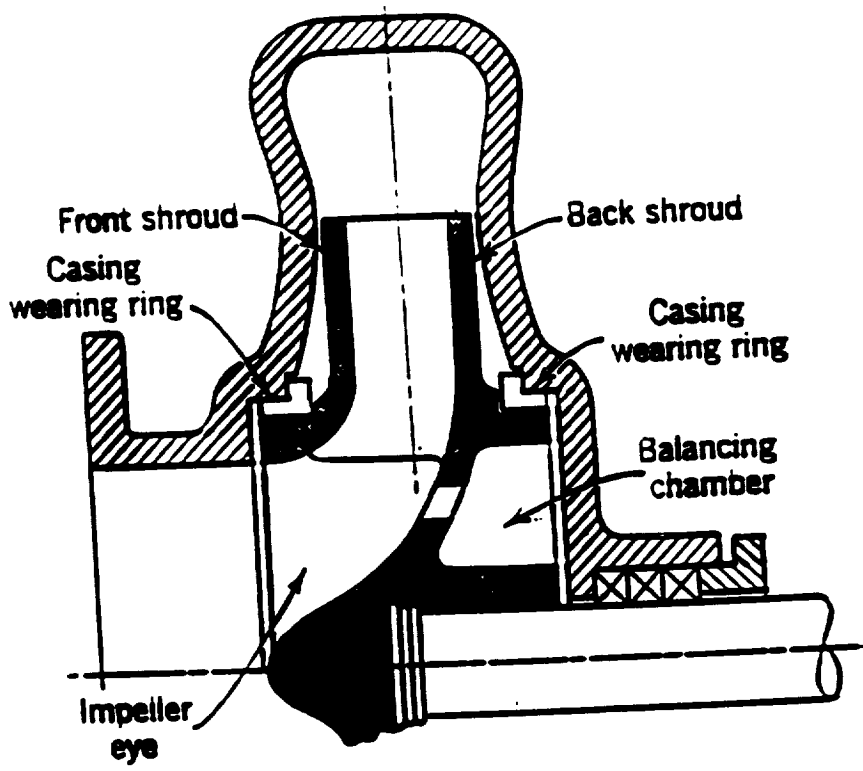

Single-suction impeller with a balancing chamber on the back.

ATD - HIGH PRESSURE OXIDIZER TURBOPUMP

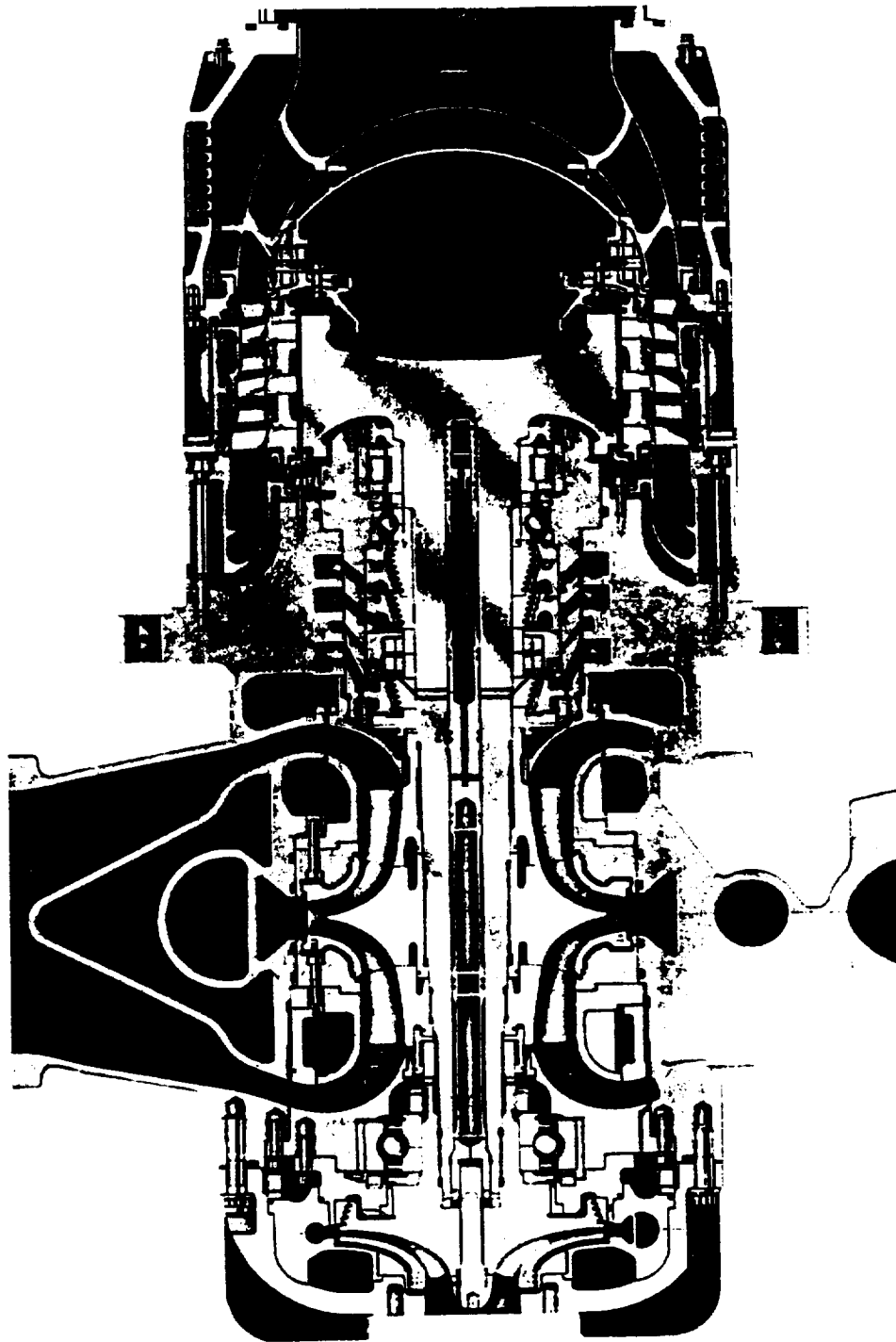

ROTORDYNAMIC FORCES

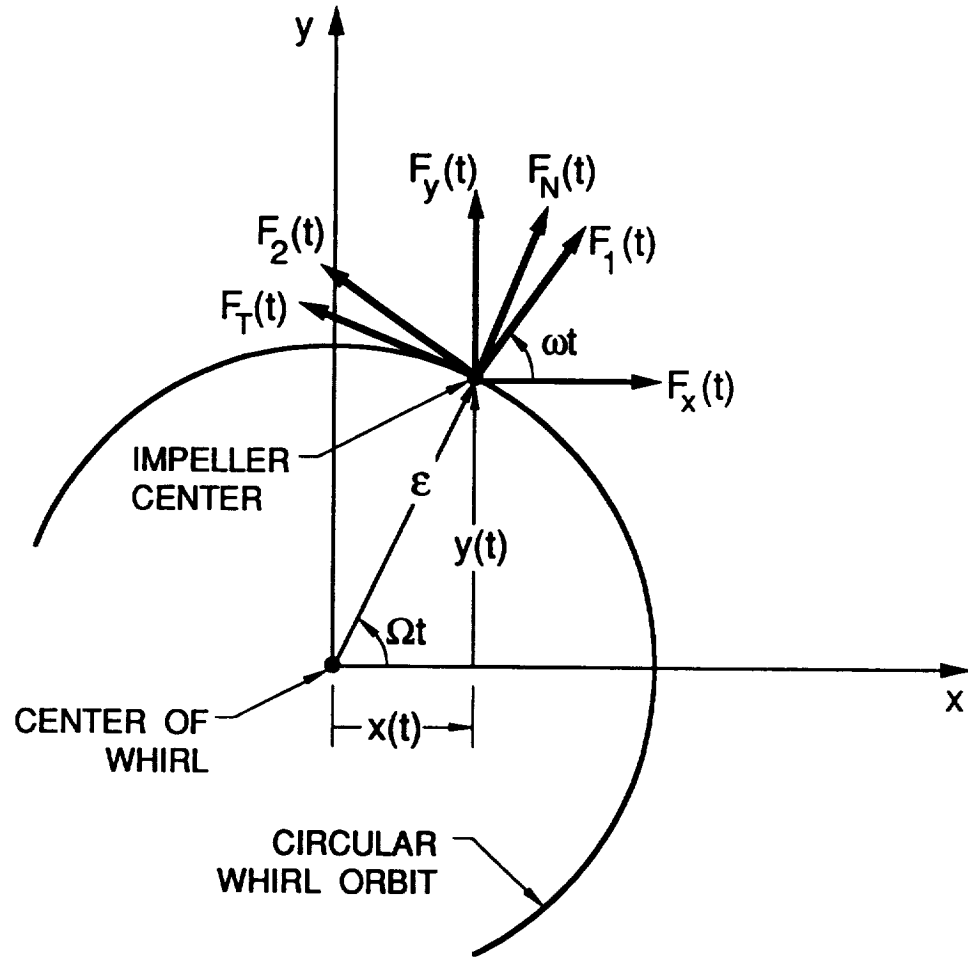

$$\begin{pmatrix} F_x(t) \\ F_y(t) \end{pmatrix} = \begin{pmatrix} F_{ox} \\ F_{oy} \end{pmatrix} + [A] \begin{pmatrix} x(t) \\ y(t) \end{pmatrix}$$

For a circular whirl orbit:

$$x^*(t) = \epsilon \cos(\Omega t)$$

$$y^*(t) = \epsilon \sin(\Omega t)$$

$$F_n^*(t) = \frac{1}{2}(A_{xx}^* + A_{yy}^*)\epsilon$$

$$F_t^*(t) = \frac{1}{2}(-A_{xy}^* + A_{yx}^*)\epsilon$$

ROTORDYNAMIC COEFFICIENTS

$$F_n = M \left(\frac{\Omega}{\omega} \right)^2 - c \left(\frac{\Omega}{\omega} \right) - K$$

$$F_t = -C \left(\frac{\Omega}{\omega} \right) + k$$

M = Direct Added Mass

C = Direct Damping

c = Cross-coupled Damping

K = Direct Stiffness

k = Cross-coupled Stiffness

k/C = Whirl Ratio

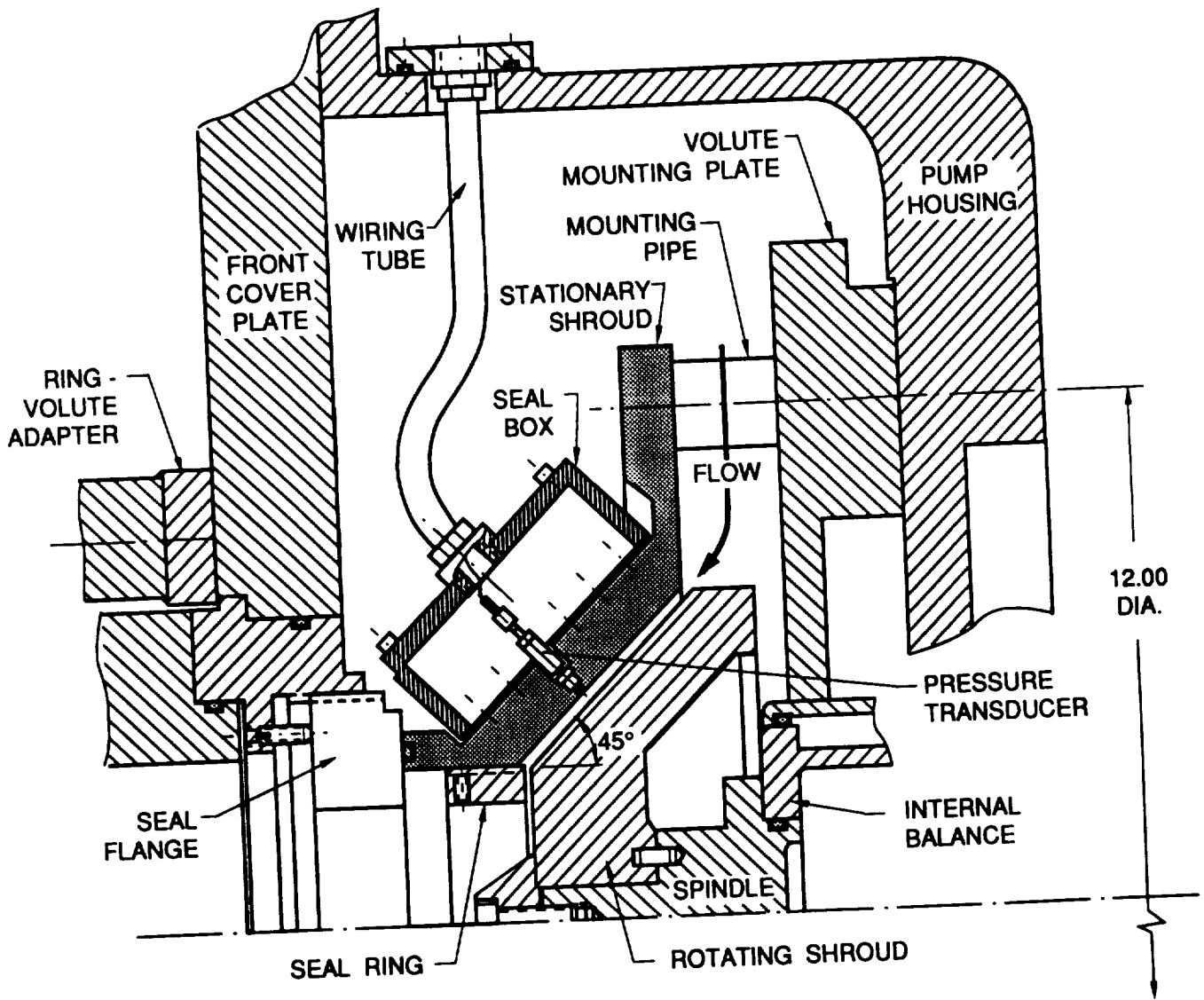

CALTECH LEAKAGE FORCE TEST APPARATUS

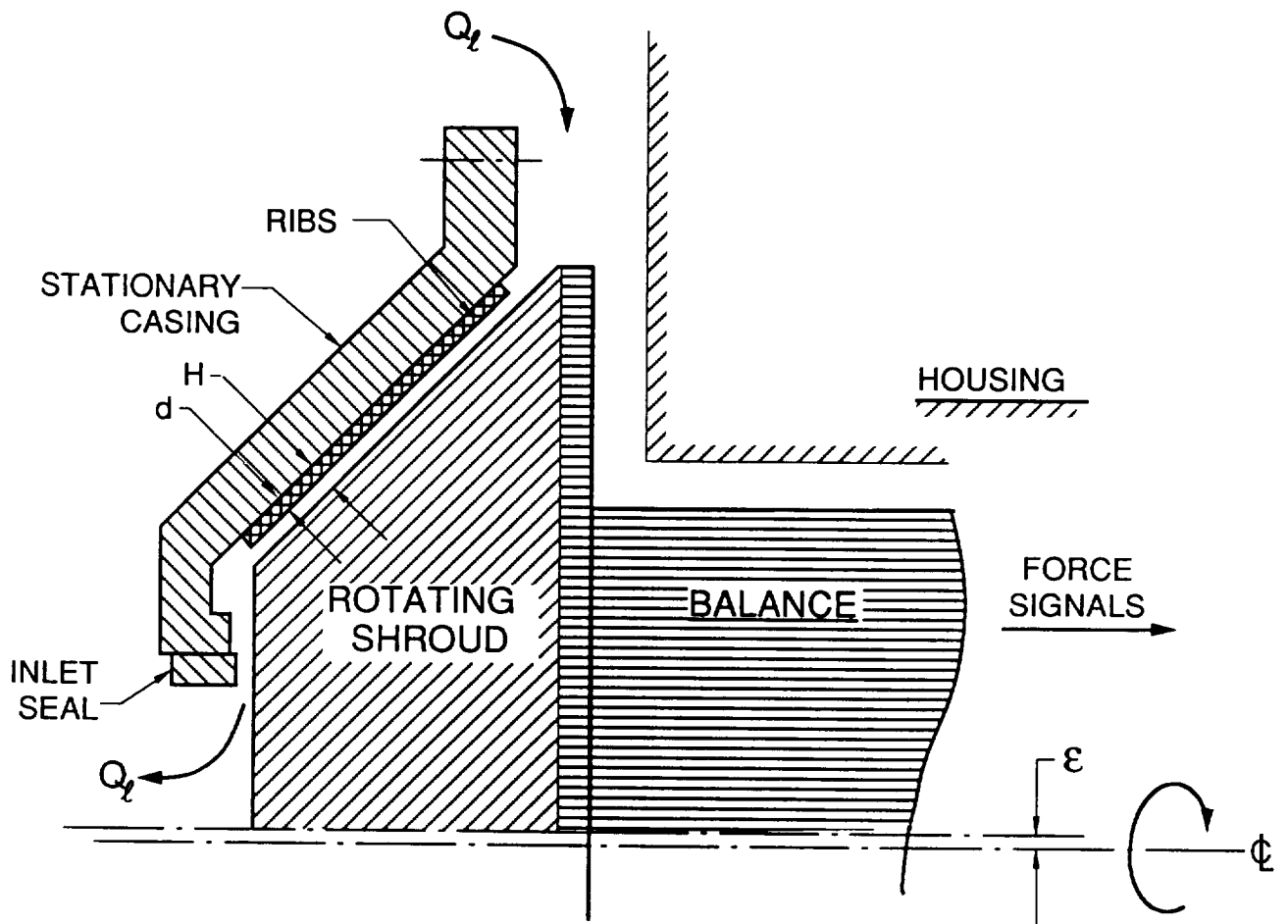

TEST MATRIX

Table 1. Tests Without Inlet Swirl

RPM	Ω/ω	Brakes	Q (GPM)	ϕ
1000	-0.9 to +0.9	0	0	0.0
			10	0.026
			20	0.052
			30	0.077
		4	0	0.0
			10	0.026
			20	0.052
			30	0.077
		8	0	0.0
			10	0.026
			20	0.052
			30	0.077
2000	-0.6 to +0.7	0	0	0.0
			10	0.013
			20	0.026
			30	0.039
		4	0	0.0
			10	0.013
			20	0.026
			30	0.039
		8	0	0.0
			10	0.013
			20	0.026
			30	0.039

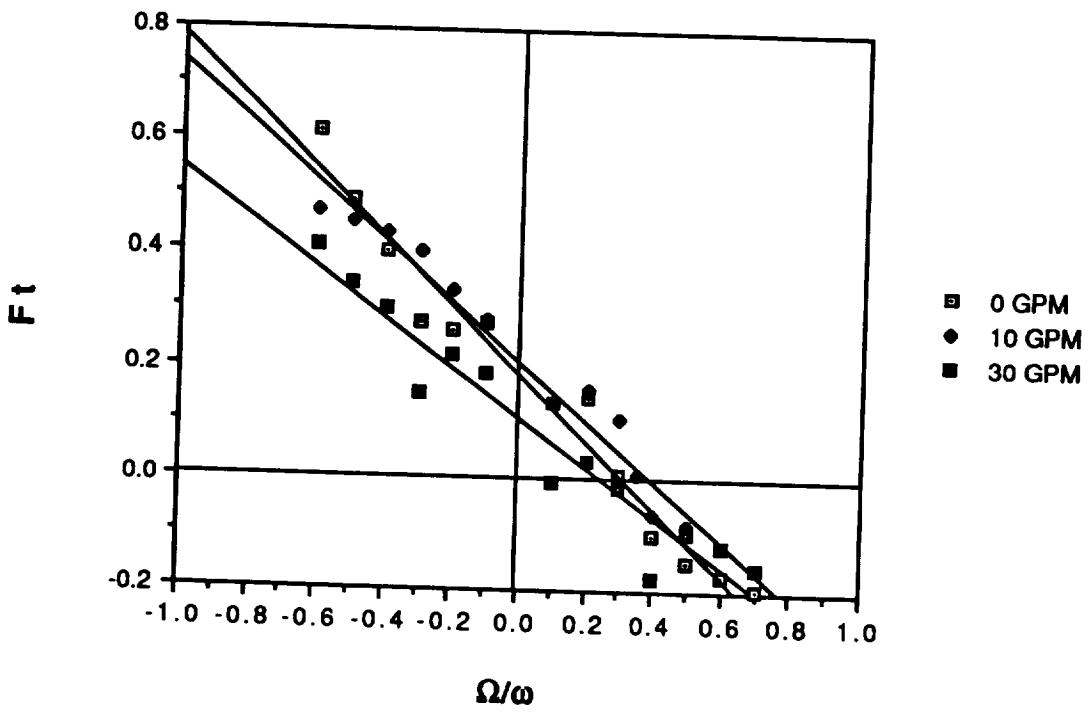
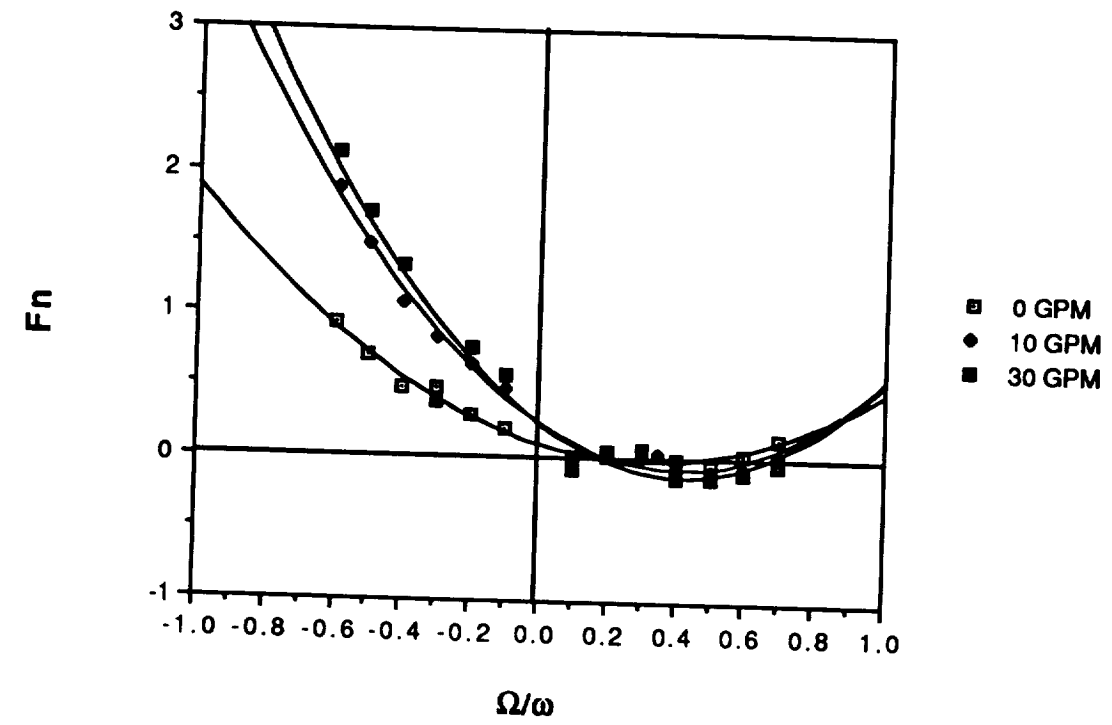

Figure (1) Dimensionless normal and tangential forces at 2000 RPM with 0 swirl brakes and flow rates of 0, 10 and 30 GPM.

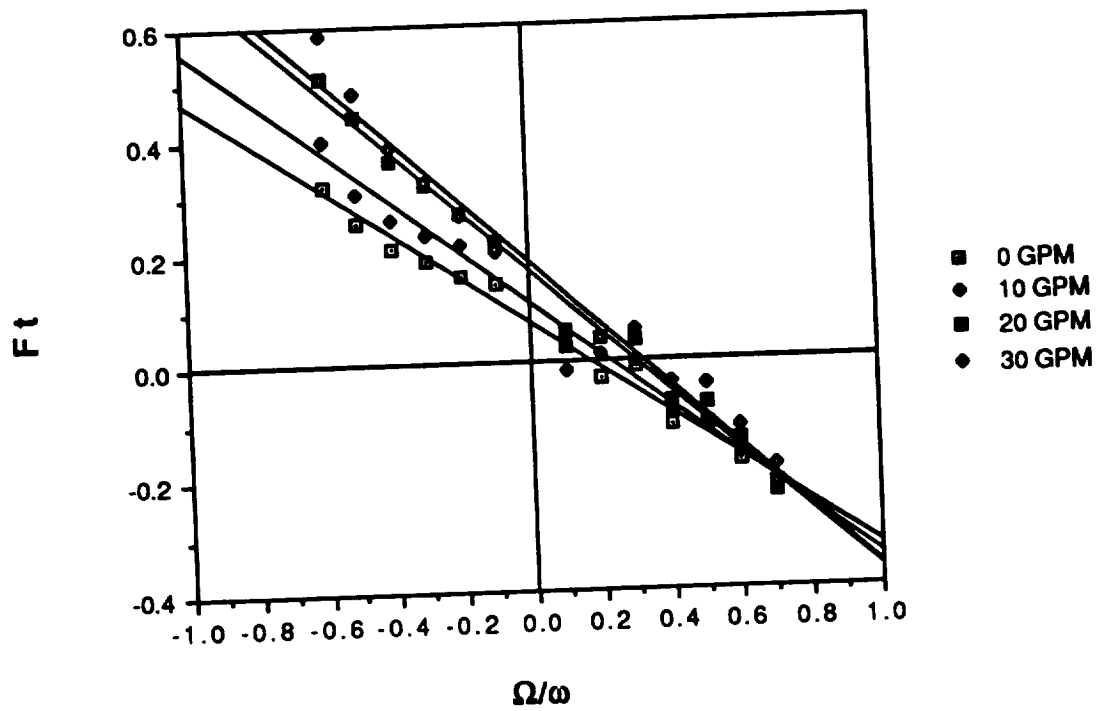
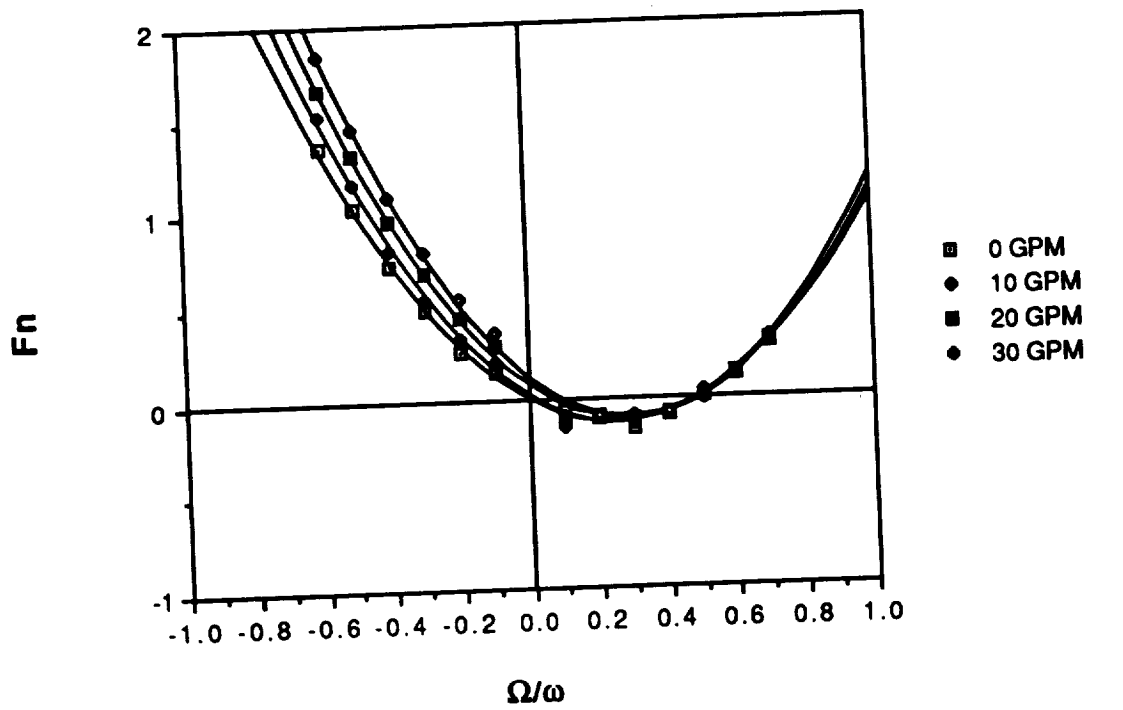

Figure (2) Dimensionless normal and tangential forces at 2000 RPM with 4 swirl brakes and flow rates of 0, 10 and 30 GPM.

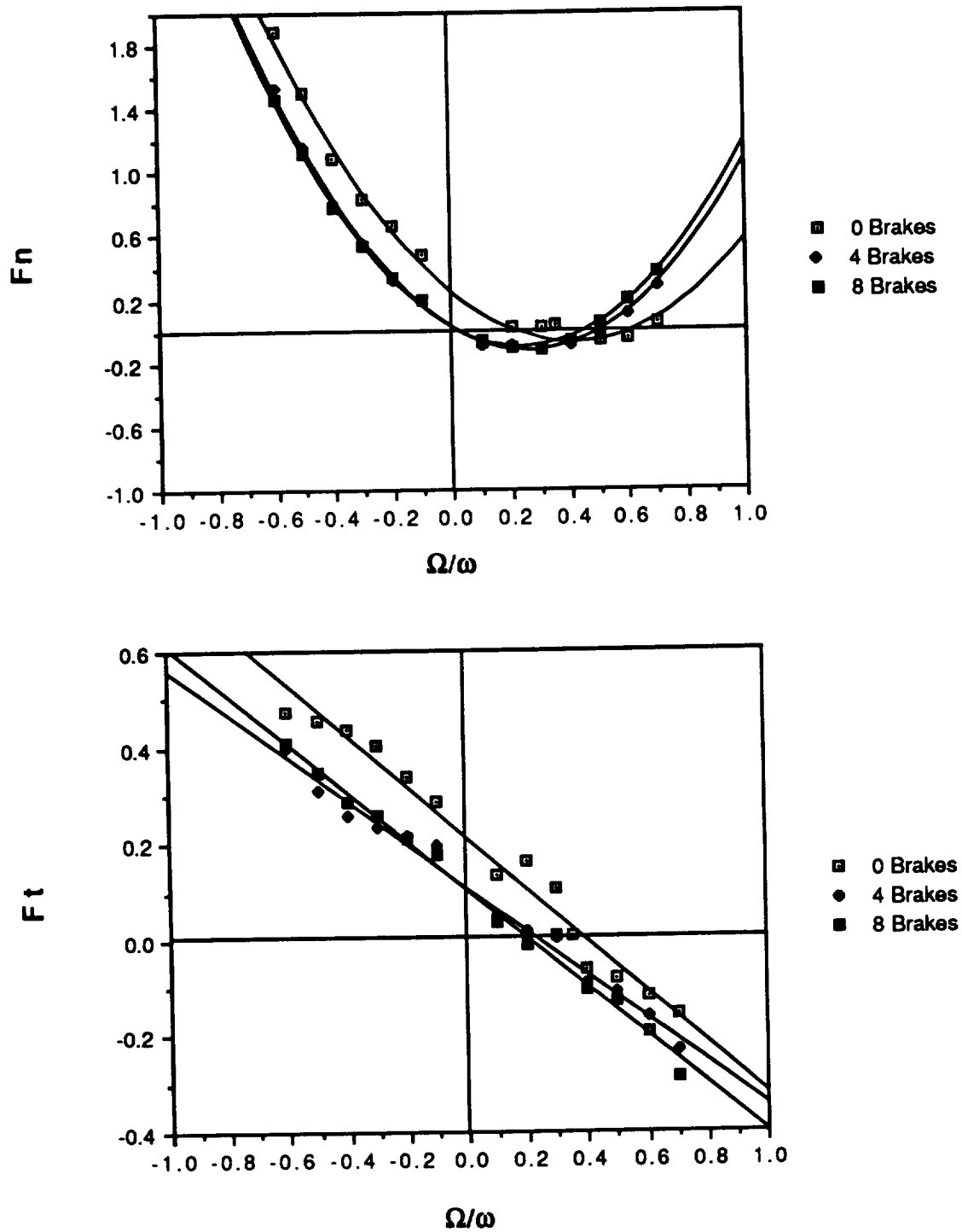

Figure (3) Dimensionless normal and tangential forces at 2000 RPM and a flow rate of 10 GPM for 0, 4 and 8 swirl brakes.

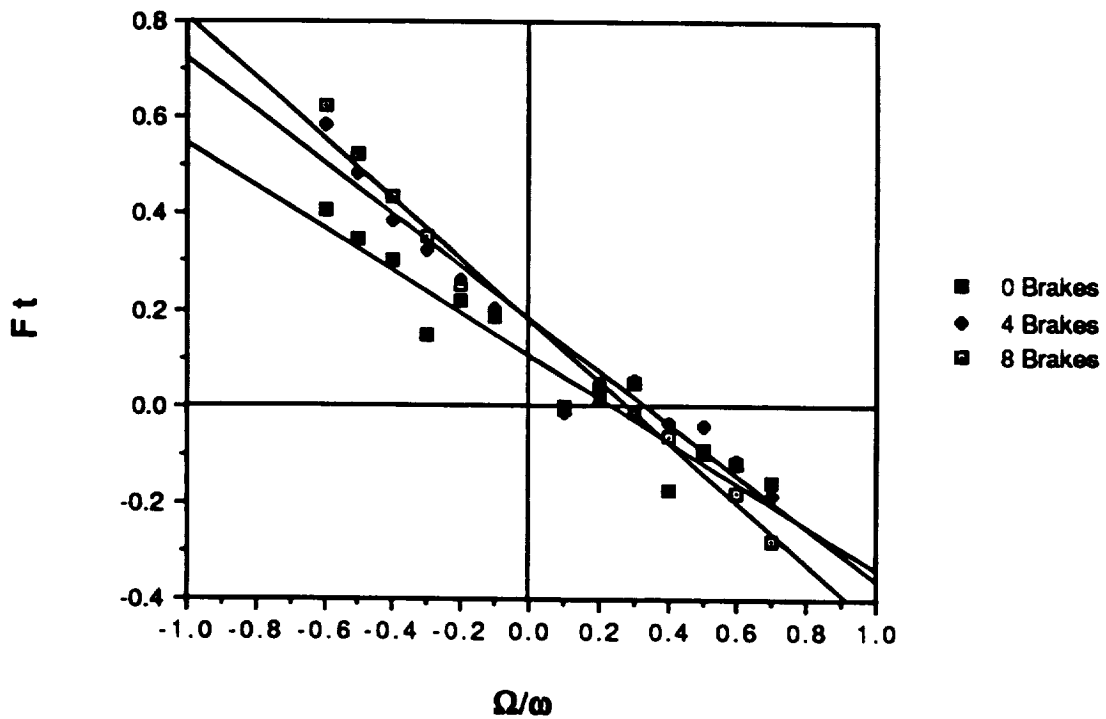
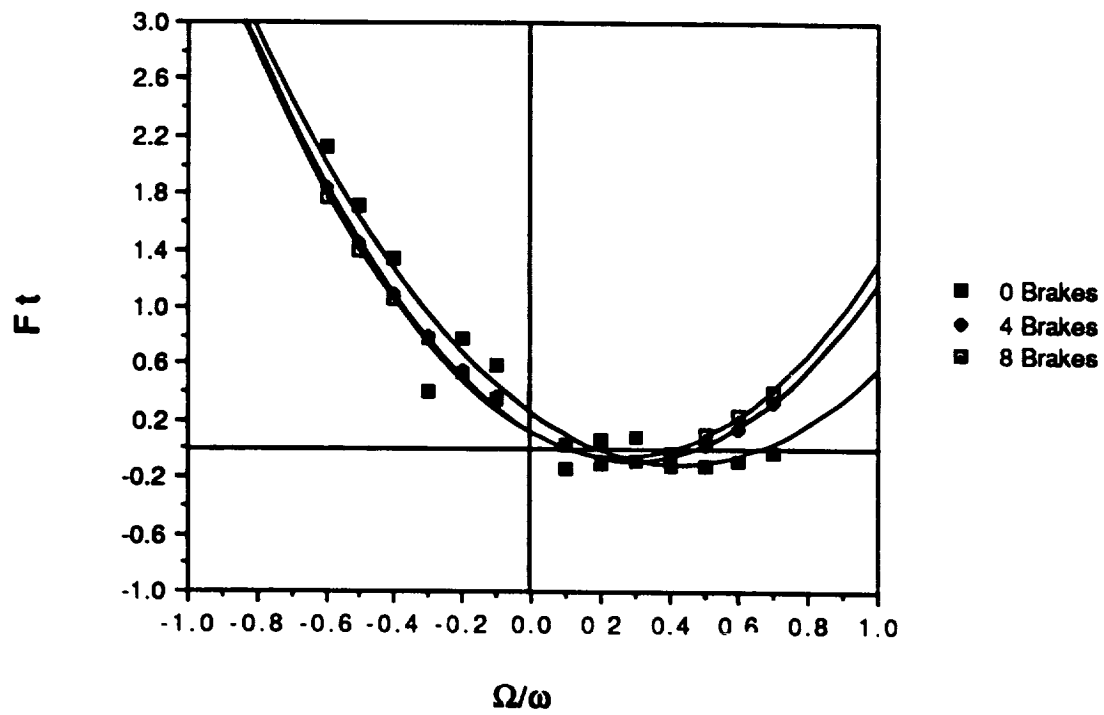
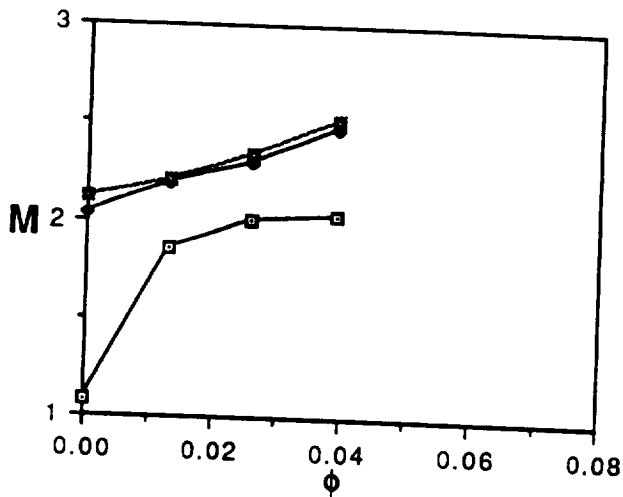
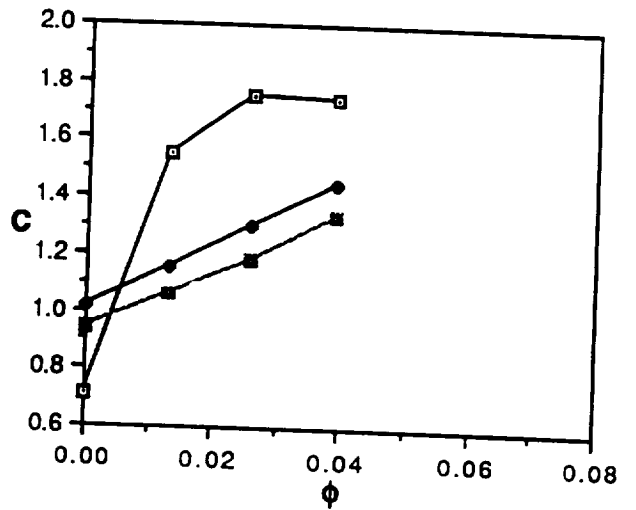
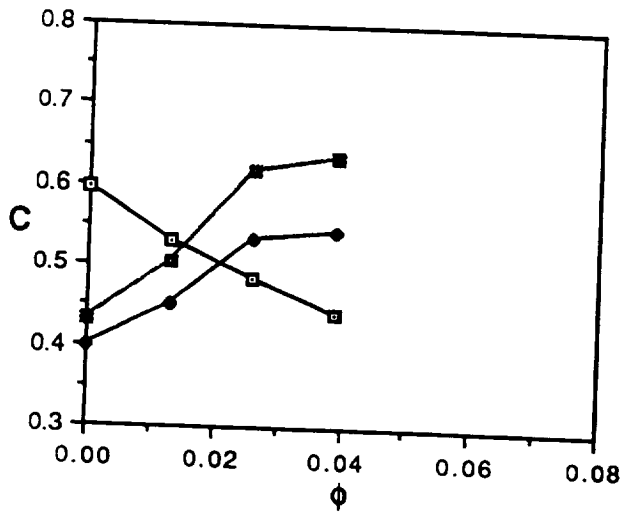
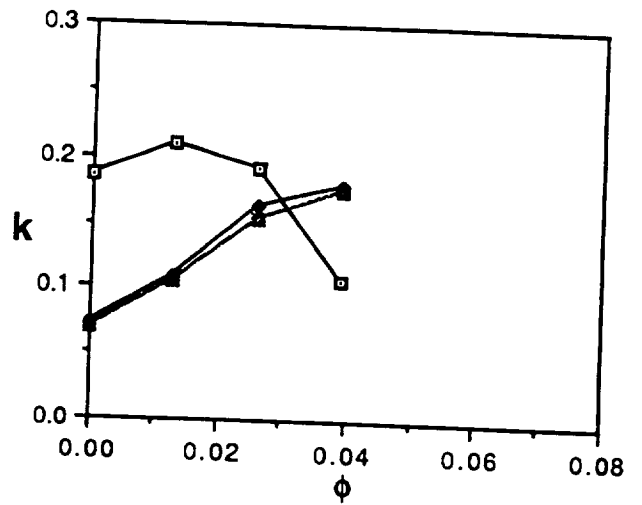
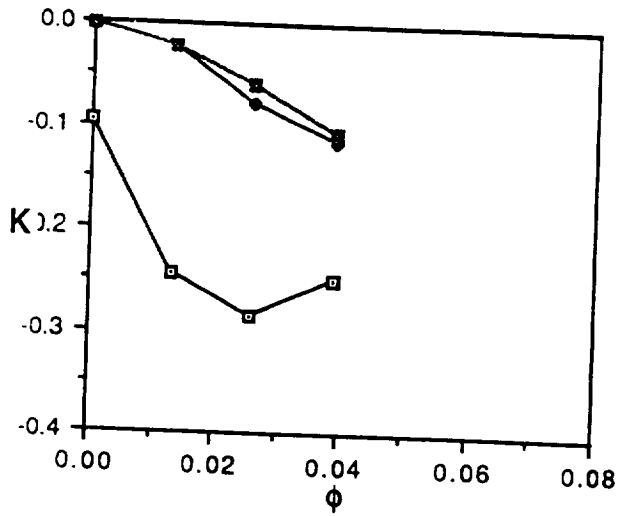

Figure (4) Dimensionless normal and tangential forces at 2000 RPM and a flow rate of 30 GPM for 0, 4 and 8 swirl brakes.



□ 0 Ribs $\omega = 2000 \text{ rpm}$
 ◆ 4 Ribs $\epsilon = 0.0465 \text{ in}$
 ■ 8 Ribs $H = 0.167 \text{ in}$

$$F_n = M \left(\frac{\Omega}{\omega} \right)^2 - c \left(\frac{\Omega}{\omega} \right) - K$$

$$F_t = -C \left(\frac{\Omega}{\omega} \right) + k$$

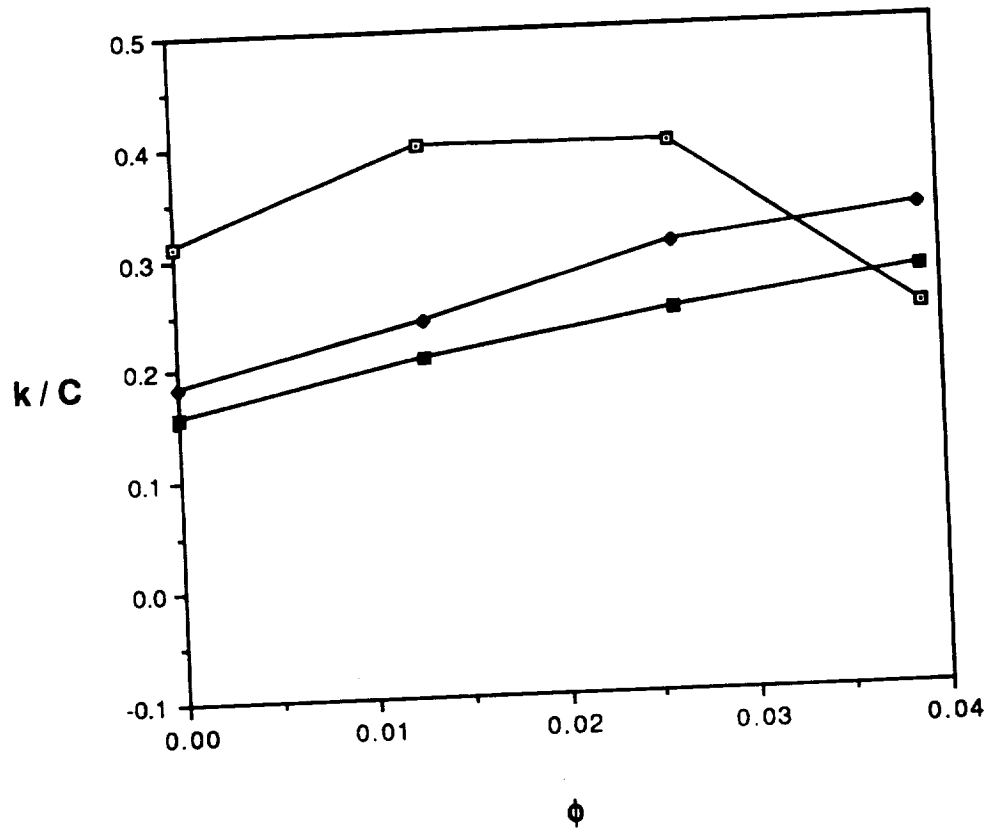

□ 0 Ribs $\omega = 2000$ rpm
 ◆ 4 Ribs $\epsilon = 0.0465$ in
 ■ 8 Ribs $H = 0.167$ in

$$F_n = M \left(\frac{\Omega}{\omega} \right)^2 - c \left(\frac{\Omega}{\omega} \right) - K$$

$$F_t = -C \left(\frac{\Omega}{\omega} \right) + k$$

CONCLUSIONS FOR PHASE 1

1. The addition of brakes reduces the destabilizing normal force for all flow rates tested.
2. For flow rates below $\phi = 0.025$, the addition of brakes reduces the tangential force and whirl ratio.

ATD - HIGH PRESSURE OXIDIZER TURBOPUMP

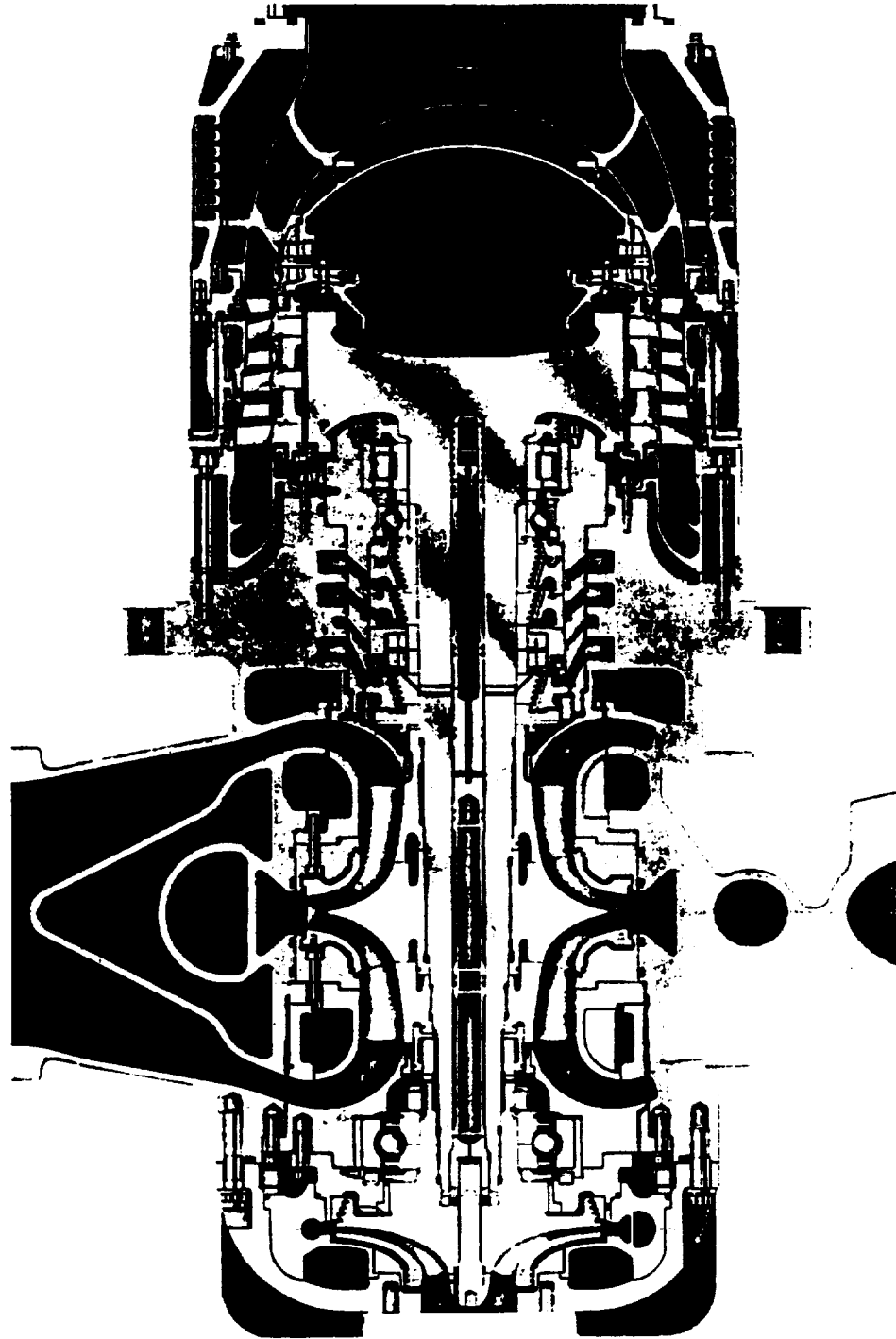

AVL380541 901810

Leakage Inlet Seal for ATD HPOTP

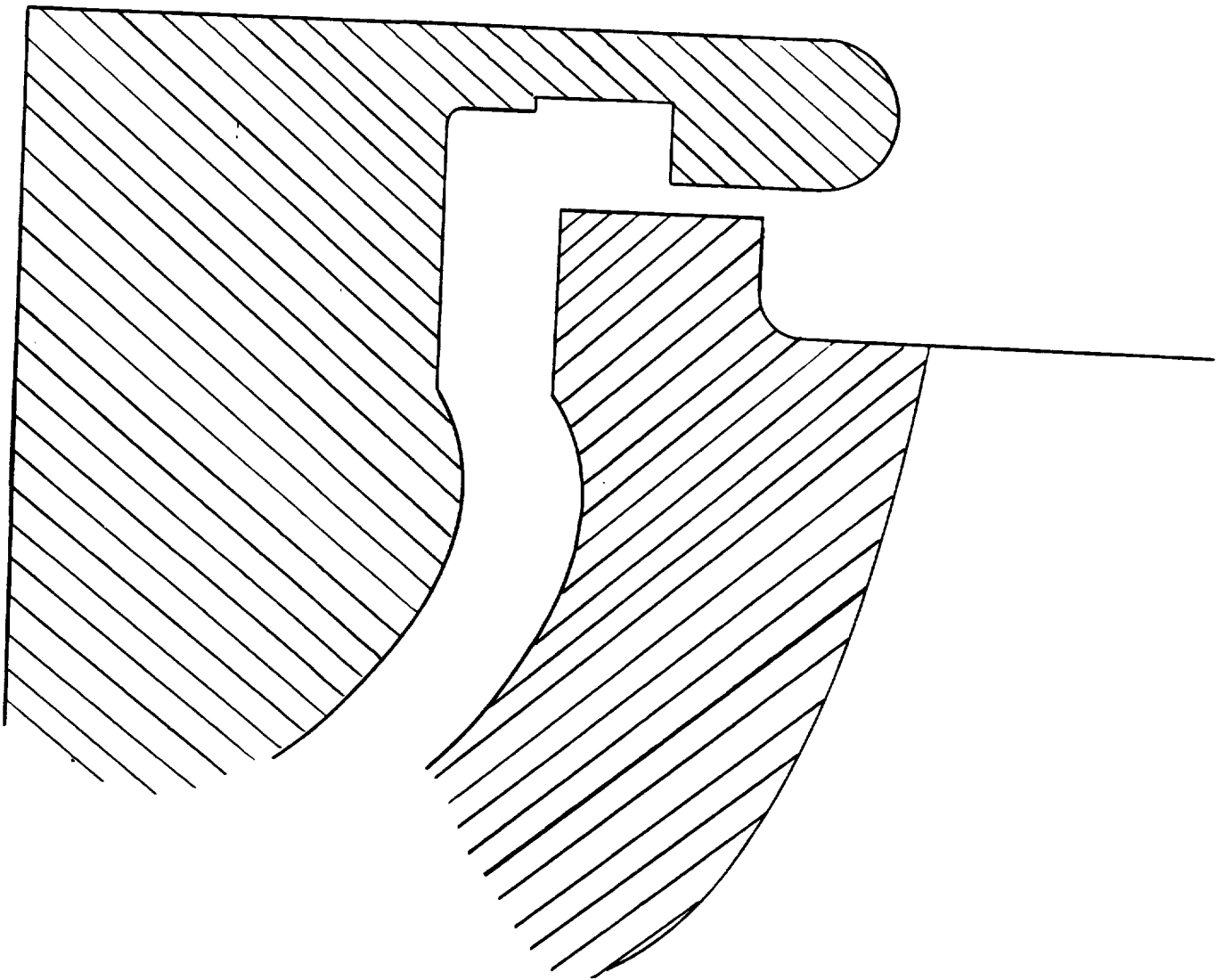

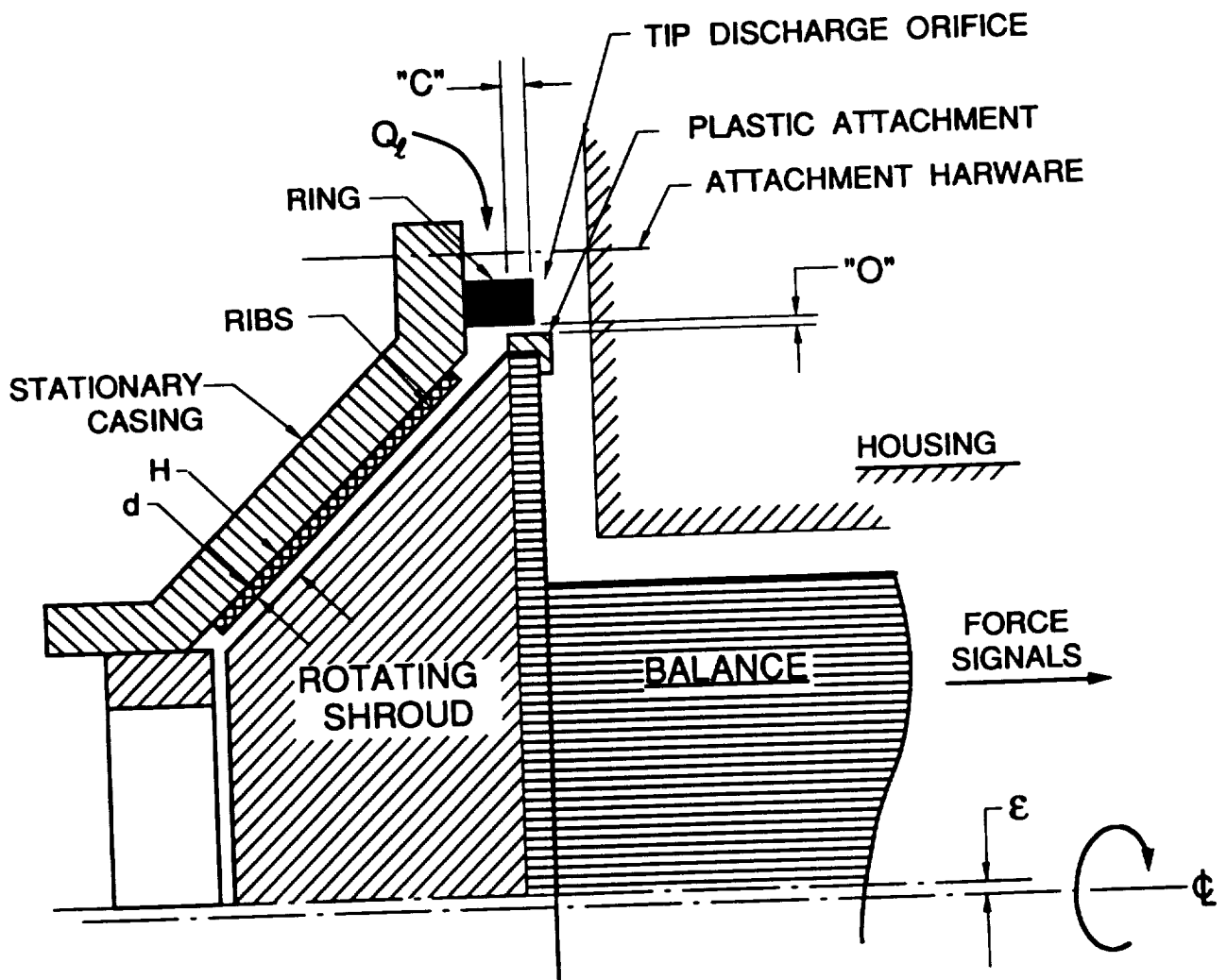

RADIAL TIP DISCHARGE ORIFICE

Comparison Plot (2000 RPM, Face Seal = 0.05 in, 10 GPM)
No Brakes

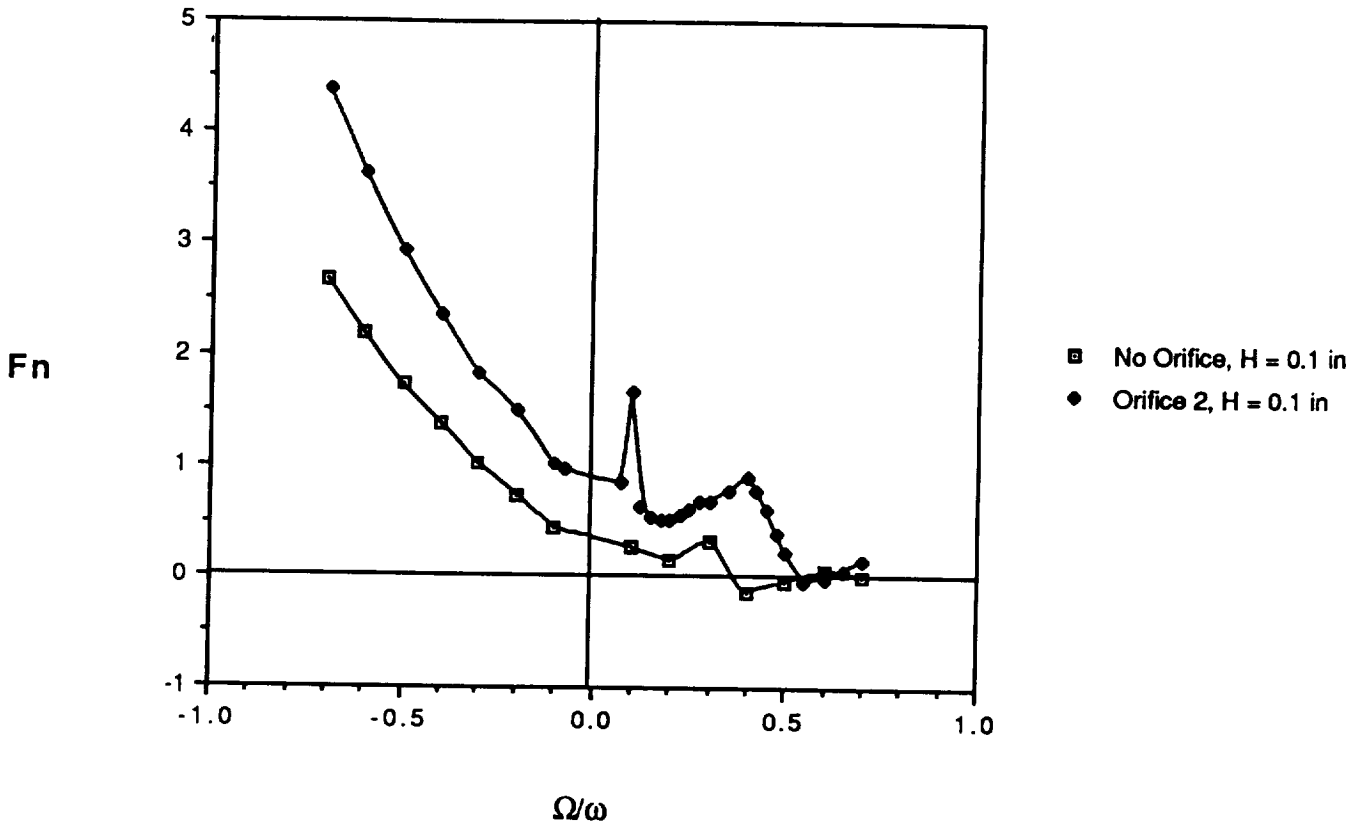

Comparison Plot (2000 RPM, Face Seal = 0.05 in, 10 GPM)
No Brakes

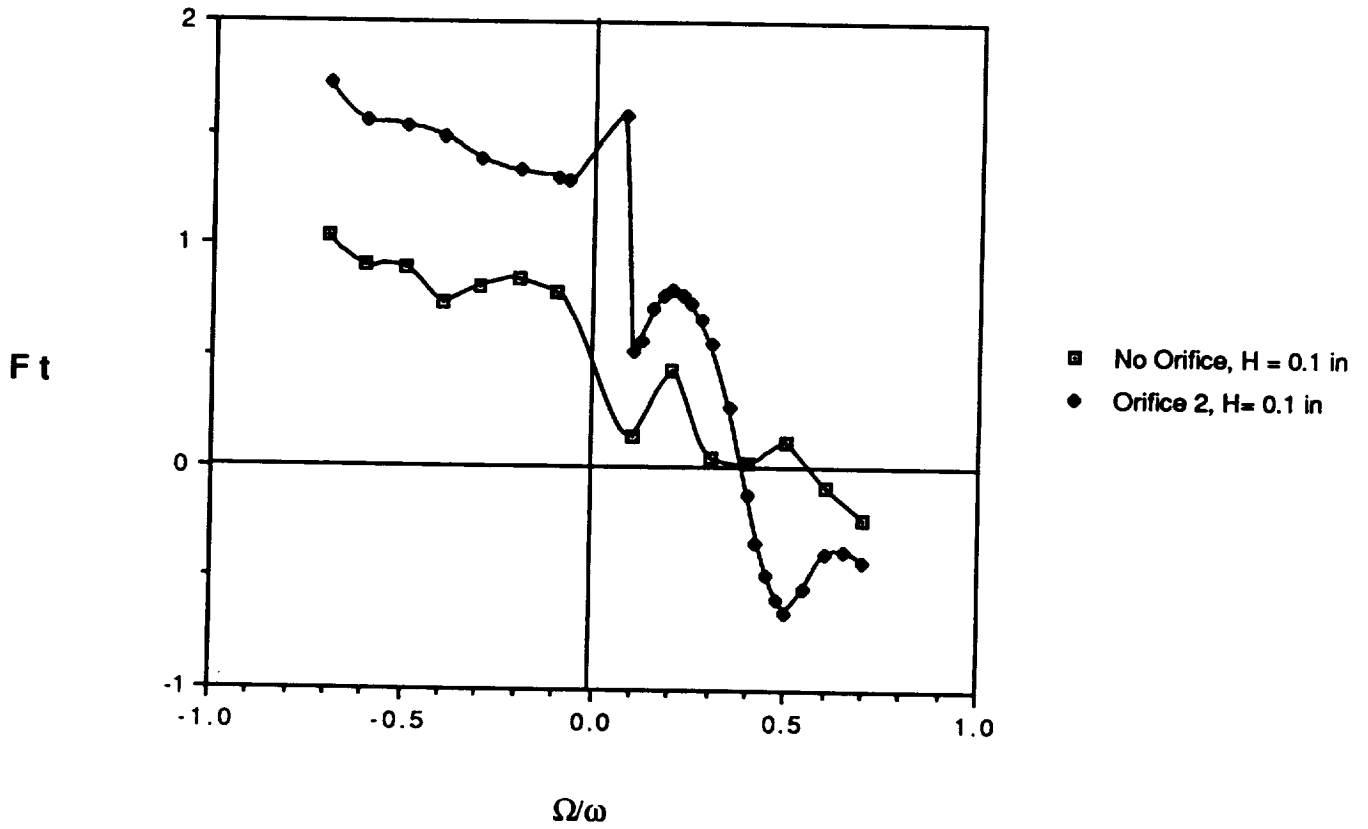

Comparison Plot (2000 RPM, Face Seal = 0.05 in, 10 GPM)
Orifice 2

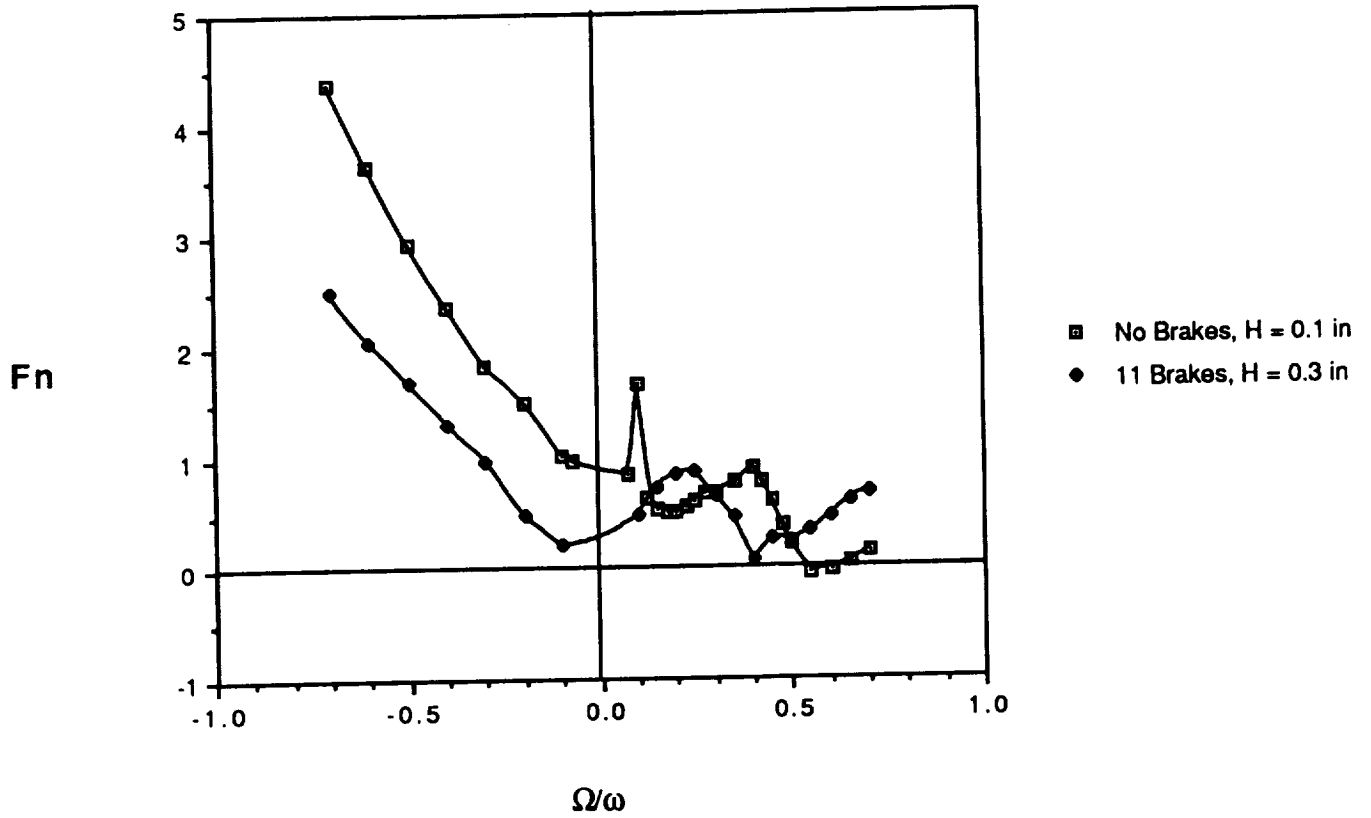

Comparison Plot (2000 RPM, Face Seal = 0.05 in, 10 GPM)
Orifice 2

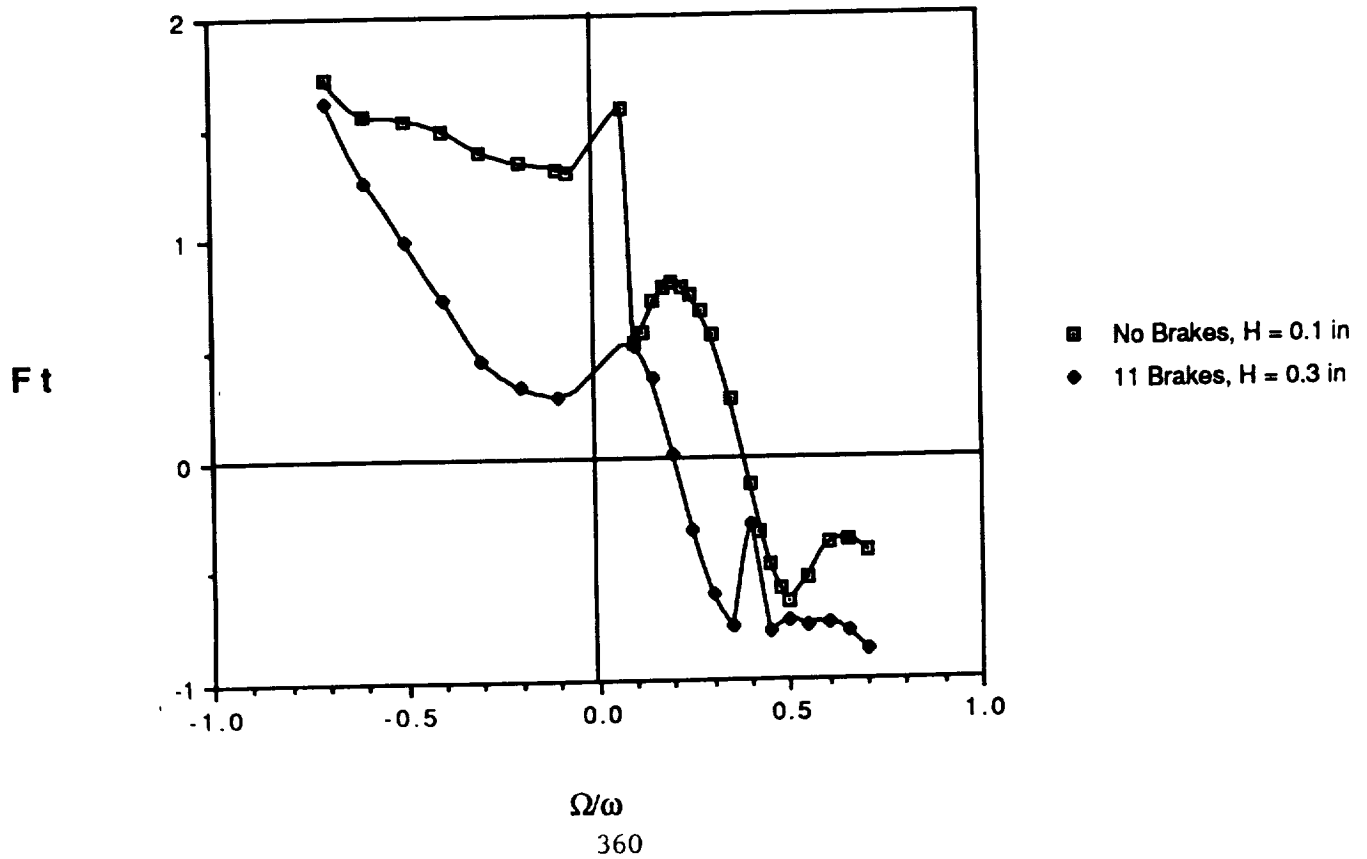

CONCLUSIONS FOR PHASE 2

1. A tip discharge orifice of the type used for the Alternate Turbopump Design (ATD) of the Space Shuttle High Pressure Oxygen Turbopump is destabilizing.
2. The design modification of widening the leakage path annular clearance and installation of 11 swirl brakes in the ATD would reduce some of the detrimental effects of the orifice.