

REPORT No. 860

ANALYSIS OF COOLING LIMITATIONS AND EFFECT OF ENGINE-COOLING IMPROVEMENTS ON LEVEL-FLIGHT CRUISING PERFORMANCE OF FOUR-ENGINE HEAVY BOMBER

By FRANK E. MARBLE, MAHLON A. MILLER, and E. BARTON BELL

SUMMARY

The NACA has developed means, including an injection impeller and ducted head baffles, to improve the cooling characteristics of the 3350-cubic-inch-displacement radial engines installed in a four-engine heavy bomber. The improvements afforded proper cooling of the rear-row exhaust-valve seats for a wide range of cowl-flap angles, mixture strengths, and airplane speeds. The results of flight tests with this airplane are used as a basis for a study to determine the manner and the extent to which the airplane performance was limited by engine cooling. By means of this analysis for both the standard airplane and the airplane with engine-cooling modifications, comparison of the specific range at particular conditions and comparison of the cruising-performance limitations were made.

The analysis of level-flight cruising performance of the airplane with both the standard- and the modified-engine installations indicated that the maximum cruising economy is attained at the minimum brake specific fuel consumption when engine cooling under these conditions is possible. Operation at lean mixtures, high altitudes, and large gross weights was limited for the standard airplane by engine cooling at the point where larger cowl-flap openings increase the power required for level flight at such a rate that the additional cooling air available is insufficient to cool the engine when developing the additional power. When cooling becomes impossible at the minimum brake specific fuel consumption, the maximum cruising economy is obtained with a cowl-flap angle of approximately 5° and with the leanest mixture (above the stoichiometric value) giving satisfactory engine cooling.

Comparison of the calculated performance of the standard and the modified airplane indicated that cooling improvements increased the maximum specific range as much as 38 percent for operation where wide cowl-flap angles and enriched mixtures are required to cool the standard airplane. Corresponding increases in cruising range were calculated for flights in which conditions allowing large increases in cruising economy were encountered. The cooling improvements allow either an increase of more than 10,000 feet in operating altitude at a given airplane weight or a gross-weight increase of from 10,000 pounds at sea level to 35,000 pounds at all operating altitudes above 10,000 feet.

INTRODUCTION

Economical cruising operation of the four-engine heavy bomber has been impaired by the rich mixtures and the large

quantities of cooling air required to cool properly the 3350-cubic-inch-displacement radial engines of this airplane. The cooling difficulties caused by nonuniform mixture distribution and poor cooling-air flow over the critical regions of the rear-row cylinders have resulted in frequent failure of the exhaust valve and the exhaust-valve seat.

The difficulties experienced in cooling the exhaust-valve seats of the rear-row cylinders have been overcome to a considerable extent by improving the mixture distribution through application of the injection impeller (reference 1) and by augmenting the flow of cooling air to the critical temperature regions through installation of ducted head baffles (reference 2). Flight tests of this airplane (reference 3) indicated that the temperatures of the exhaust-valve seats on rear-row cylinders were markedly lowered by these modifications and that airplane range, altitude, and gross weight previously limited by these temperatures could be greatly increased. Under most normal flight conditions, reasonable operating temperatures of the rear-row exhaust-valve seats were attained with the standard-engine installation for this airplane only through use of large cowl-flap angles as well as enriched mixtures. The rear-row exhaust-valve seats of the modified installation, however, were properly cooled over wide ranges of cowl-flap angles and mixture strengths, thereby affording the possibility of improving the airplane performance through proper adjustments in cowl-flap and mixture-control setting. Although the maximum performance is attained where both fuel consumption and cowl-flap angle are reduced to minimum values, it is usually necessary to increase one when the other is decreased in order to avoid exceeding the limiting cylinder temperature. In order to use advantageously the improved airplane performance afforded by the engine modifications, the combination of cowl-flap angle and mixture strength that gives the optimum cruising performance with proper cooling must be determined. The possibility of extended airplane performance formerly prohibited by cooling difficulties must be investigated to evaluate fully the effectiveness of the cooling improvement.

Flight-test data of this four-engine heavy bomber obtained at the NACA Cleveland laboratory in 1944, are evaluated and analytically extended herein to show the effect of the injection impeller and ducted head baffles on the airplane performance. The relative effects of cowl-flap angle and specific fuel consumption on the specific range of the air-

plane with standard and modified engines are determined as well as the combinations affording the maximum specific range. With the maximum specific range used as a criterion, the effects of the engine-cooling improvements on the specific range and the cooling limits of operation are computed. The calculations cover cruising conditions at altitudes from sea level to 35,000 feet and airplane weights from 75,000 to 150,000 pounds.

SYMBOLS

The following symbols are used in this report:

A	effective aspect ratio
C_D	over-all drag coefficient
$C_{D,p}$	basic parasite-drag coefficient
C_L	lift coefficient
$C_p(\phi)$	cooling-air pressure-drop coefficient, $\frac{\Delta p}{\frac{1}{2}\rho V^2}$
c	brake specific fuel consumption, pounds per brake horsepower-hour
E	specific range, miles per pound of fuel
M	combustion-air mass flow, pounds per second
P	power per engine, brake horsepower
Δp	cooling-air pressure drop, inches of water
q	free-stream dynamic pressure, $\frac{1}{2}\rho V^2$, pounds per square foot
R	airplane level-flight cruising range, miles
s	distance, miles
T_a	cooling-air temperature ahead of engine, °F
T_g	effective combustion-gas temperature, °F
T_h	cylinder-head temperature, °F
V	true airspeed, miles per hour
W	airplane gross weight, pounds
W_0	gross weight of airplane without fuel, pounds
W_f	weight of fuel, pounds
$\alpha(\phi)$	incremental drag coefficient resulting from cowl-flap angle
ρ	air density, slugs per cubic foot
ρ_0	air density (standard sea-level Army summer air, 0.00221), slugs per cubic foot
σ	ratio of free-air density to standard-air density, ρ/ρ_0
$\sqrt{\sigma P}$	apparent brake horsepower
$\sqrt{\sigma V}$	indicated airspeed, miles per hour
ϕ	cowl-flap angle, degrees

The subscript 0 represents sea-level reference conditions.

ANALYSIS

The improvement in airplane cruising performance effected by cooling improvements may be demonstrated by comparing cruising range and cooling-limited performance of standard- and modified-engine installations. This comparison requires that the conditions for best cruising economy, as well as the true nature of the limitations, be analyzed. In order to undertake this analysis with sufficient accuracy and for a wide variety of airplane operating conditions, it is necessary

to investigate the relations among the airplane performance, the engine performance, the engine cooling characteristics, and the associated variables.

AIRPLANE CRUISING RANGE

The specific range of an airplane, that is, the distance that may be flown for each pound of fuel expended at a given altitude, speed, and gross weight, may be expressed analytically by

$$E = -\frac{ds}{dW_f} \quad (1)$$

where the minus sign indicates that the fuel weight decreases during flight. Consequently, the range of the airplane may be written as

$$R = \int_0^R ds = -\int_{W_0}^{W_0+W_f} EdW_f \quad (2)$$

where the integration covers weights from full to empty fuel supply. The variable of integration and the appropriate limits may refer to either the fuel weight or the gross airplane weight because the variations of one are the same as those of the other if oil consumption and abrupt changes of gross weight, such as disposal of bombs, are neglected. The gross airplane weight is more convenient than the fuel weight inasmuch as it directly influences the specific range.

The most accurate evaluation of equation (2) requires numerical methods because the quantities affecting the integrand vary with gross airplane weight in ways that are difficult to express analytically. Because of these interrelations, the specific range, and consequently the airplane cruising range, are functions of several variables not all of which are independent. Both the gross weight of the airplane and the cruising altitude are usually fixed by conditions other than specific range. The optimum cruising conditions for any particular airplane weight and cruising altitude are therefore the values of the remaining variables that give the integral in equation (2) a maximum value and at the same time provide proper cooling.

SPECIFIC RANGE

Method of solution.—In order to calculate the specific range of the four-engine heavy bomber, it was necessary to have in either analytical or graphical form the aerodynamic characteristics of the airplane, the engine operating performance, and the engine cooling requirements. These variables are not independent but are related through the requirements that the engine be properly cooled and that the airplane be maintained in level flight.

For a given altitude and gross airplane weight, the physical relations among the variables that define the specific range are:

1. Power required by the airplane for steady level flight—determined by the airplane speed and the cowl-flap opening

2. Cooling-air pressure drop required to cool the engine to the limiting head temperature—determined by the engine power output and the brake specific fuel consumption
3. Cooling-air pressure drop available across the engine (necessarily equal to the pressure drop required when operating at the limiting head temperature)—determined by the airplane speed and the cowl-flap opening

Together with the definition of specific range, these relations form a set of four simultaneous algebraic equations in six variables. Four of these variables can therefore be eliminated and the cruising economy expressed in terms of any two. The airplane speed and the brake specific fuel consumption are considered the independent variables and the maximum values of specific range with respect to these variables are determined by graphical means.

Assumptions for calculations.—The analysis was based on standard Army summer air conditions and on the conservative temperature limit of 560° F at the exhaust-valve seat (corresponding to a limit between 420° and 440° F at the rear spark-plug gasket of the standard engine) of the hottest rear-row cylinder. It was assumed that limiting exhaust-valve-seat temperatures would not be encountered on the front-row cylinders where the critical regions are more adequately cooled. The relation between the engine speed and the engine power was taken to be a propeller-load curve (fig. 1) defined by the rated engine conditions. The resulting indicated mean effective pressures were below the knock limit for all fuel-air ratios. For operation along the propeller-load curve, the relation between brake specific fuel consumption and fuel-air ratio (fig. 2) was approximated from flight-test results and from estimates of the engine manufacturer. The analytical performance comparison for the airplane with standard- and modified-engine installations should be materially unaffected by the approximate nature of this relation because brake horsepowers above the normal rated 2000 for the engine were not used in the calculations.

RELATIONS AMONG FUNDAMENTAL VARIABLES

The formulation of the relations affecting the airplane cruising economy necessitates analysis of these flight tests. Each of the three fundamental relations will be considered separately.

Brake horsepower required.—An analytical approximation of the brake horsepower required for level flight may be found when the relation between the lift and the drag coefficients of the airplane are known. If the airplane is considered an elliptically loaded wing of finite span (reference 4), the drag coefficient may be expressed as the sum of the parasite and the induced drag coefficients

$$C_D = C_{D,p}[1 + \alpha(\phi)] + \frac{C_L^2}{\pi A} \quad (3)$$

where the incremental drag coefficient $\alpha(\phi)$ accounts for the additional drag resulting from the cooling-air momentum loss

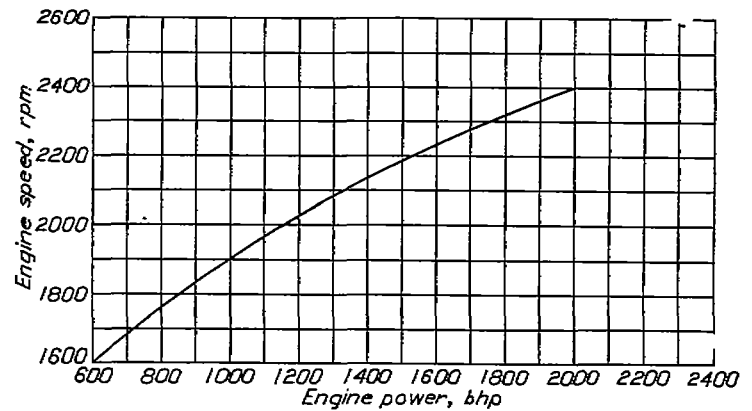

FIGURE 1.—Relation between engine power and engine speed corresponding to propeller-load curve based on rated engine conditions.

and the true parasite drag of the cowl flaps. The coefficient was based on a wing area of 1750 square feet. Numerical values of the parasite drag coefficient with closed cowl flaps $C_{D,p,0}$ and the effective aspect ratio of the equivalent elliptically loaded wing A , as well as the relation between the incremental drag coefficient and the cowl-flap angle, can be determined.

In order to obtain values of the unknown quantities of equation (3), a limited number of flight tests with the airplane were undertaken in which airspeed, altitude, and other pertinent flight data were accurately measured. The brake horsepower was determined on two of the four radial engines of 3350-cubic-inch displacement from torquemeter readings and was estimated for the other two engines from carefully observed engine operating conditions. The weight of the airplane was approximated from the known weight of the empty airplane and the approximated weights of equipment, personnel, and fuel at the particular time of test.

The method of relating the power requirements to the lift and drag coefficients is well known and its application to the generalization of flight-test data is thoroughly discussed in references 5 and 6. The linear relation between the over-all drag coefficient (closed cowl flaps) and the square of the lift coefficient was determined from flight tests at

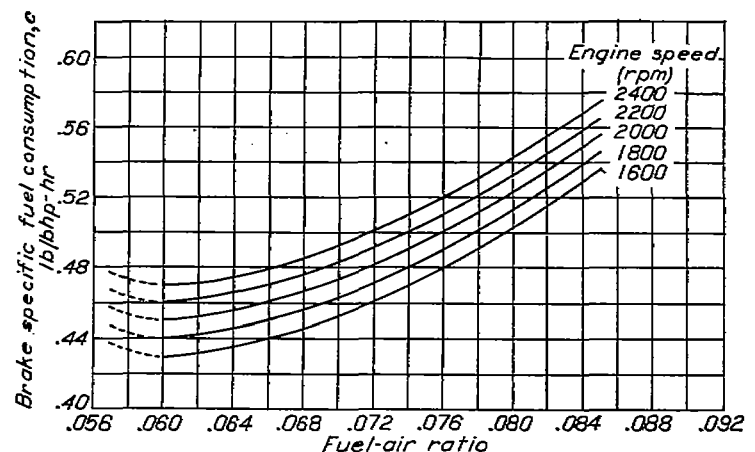

FIGURE 2.—Approximate variation of brake specific fuel consumption with over-all fuel-air ratio for various engine speeds.

two engine speeds for an assumed constant propulsive efficiency of 0.85 and is shown in figure 3. Because of this assumption and because the airplane weight was not precisely known, the data for the different engine speeds are not in complete agreement but define two parallel lines. The approximation used in the following analysis was made by drawing a line parallel to and equidistant from the lines defined by each set of points. The experimental values of the basic parasite-drag coefficient and the effective aspect ratio may be determined from figure 3 and equation (3) as

$$C_{D,p} = 0.021$$

$$A = 8.4$$

The relation between the incremental drag coefficient $\alpha(\phi)$ and the cowl-flap angle ϕ (fig. 4) was determined from flight tests covering the normal range of cowl-flap angles.

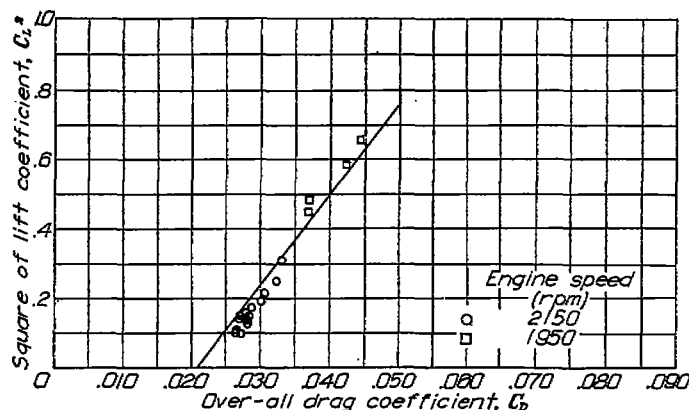

FIGURE 3.—Relation between square of lift coefficient and drag coefficient. Cowl flaps at 2° (closed) position; propulsive efficiency, 0.85.

From the foregoing results, the apparent brake-horsepower requirement per engine $\sqrt{\sigma}P$ may be conveniently expressed in terms of the reduced variables (airspeed, mph; and airplane weight, lb) where the propulsive efficiency is assumed to be 0.85 and the wing area is 1750 square feet

$$\frac{\sqrt{\sigma}P}{(W/100,000)^{3/2}} = 6.9 \times 10^{-5} [1 + \alpha(\phi)] \left(\frac{\sqrt{\sigma}V}{\sqrt{W/100,000}} \right)^3 + 710 \left(\frac{\sqrt{\sigma}V}{\sqrt{W/100,000}} \right)^{-1} \quad (4)$$

The value of the incremental drag coefficient $\alpha(\phi)$ is chosen from figure 4 corresponding to given cowl-flap angles. The relation between the required brake horsepower per engine and the indicated airspeed is graphically shown in figure 5 for the useful range of cowl-flap angles. Because the analysis was made with a constant propulsive efficiency, the values of power calculated from equation (4) will undoubtedly be in error for both very high and very low airspeeds but is believed accurate within ± 3 percent for values of reduced indicated airspeed $\frac{\sqrt{\sigma}V}{\sqrt{W/100,000}}$ between 170 and 230 miles per hour.

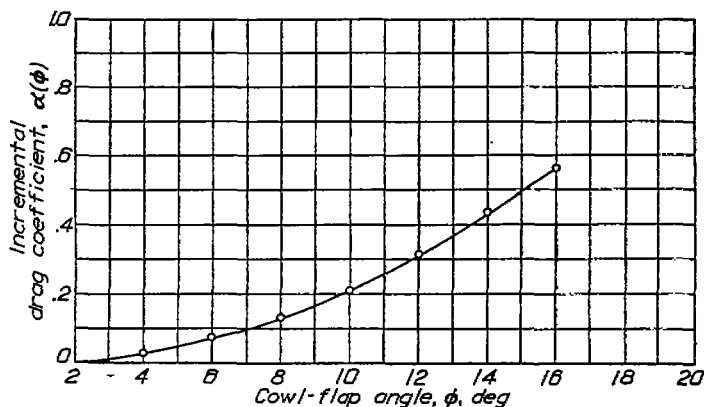

FIGURE 4.—Incremental drag coefficient for various cowl-flap angles.

Available cooling-air pressure drop.—Because no measurements of the cooling-air pressures were made during flight tests of the airplane, it was necessary to estimate the pressure drop available for cooling from wind-tunnel tests of the same engine installation (reference 7). If the effects of inclination of the thrust axis and of air compressibility are neglected, the relation between cooling-air pressure drop, airplane speed, and cowl-flap angle may be expressed as

$$\frac{\Delta p}{q} = \frac{\Delta p}{\frac{1}{2}\rho V^2} = C_p(\phi) \quad (5)$$

where the cooling-air pressure-drop coefficient $C_p(\phi)$ depends only on the cowl-flap angle. The cooling-air pressure-drop coefficient was corrected for wind-tunnel wall interference by applying the correction of reference 8 to the pressure down-

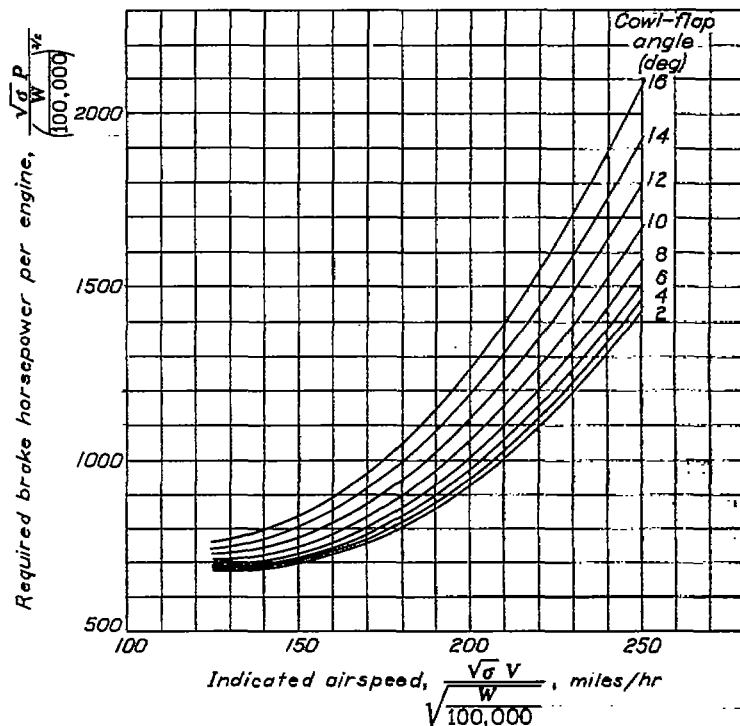

FIGURE 5.—Approximate power required by four-engine heavy bomber for level-flight cruising.

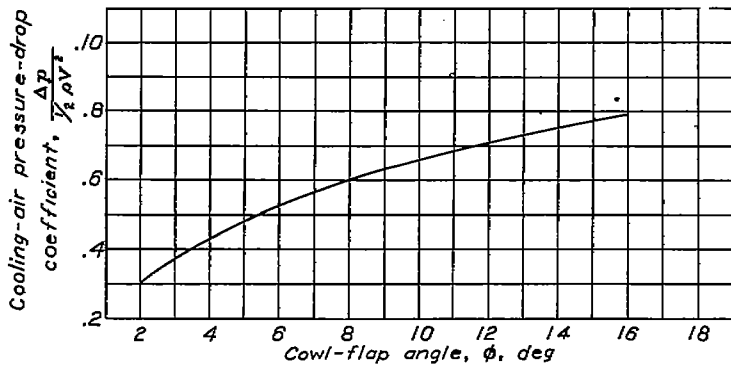

FIGURE 6.—Variation of cooling-air pressure-drop coefficient with cowl-flap angle. (Data from reference 7, corrected for wind-tunnel wall interference.)

stream of the engine rather than to the pressure at the cowl-flap exit. The resulting corrected values of $\frac{\Delta p}{\frac{1}{2}\rho V^2}$ are shown in figure 6 for the useful range of cowl-flap angles.

Engine cooling characteristics.—The cooling data from flight tests of the airplane with standard- and modified-engine installations were correlated in the manner of reference 9, using the relation given in figure 6 for estimating the cooling-air pressure drop. The flight tests undertaken for this purpose and the details of the correlation procedure are discussed in reference 3. Because difficulties have been experienced in cooling the exhaust-valve seats of the rear-row cylinders and because the cooling limitations are prescribed by the temperature of the hottest cylinder, the cooling relations are based on the maximum temperatures of the rear-row exhaust-valve seats. The correlated results of the flight tests of the standard-engine installation and of the modified

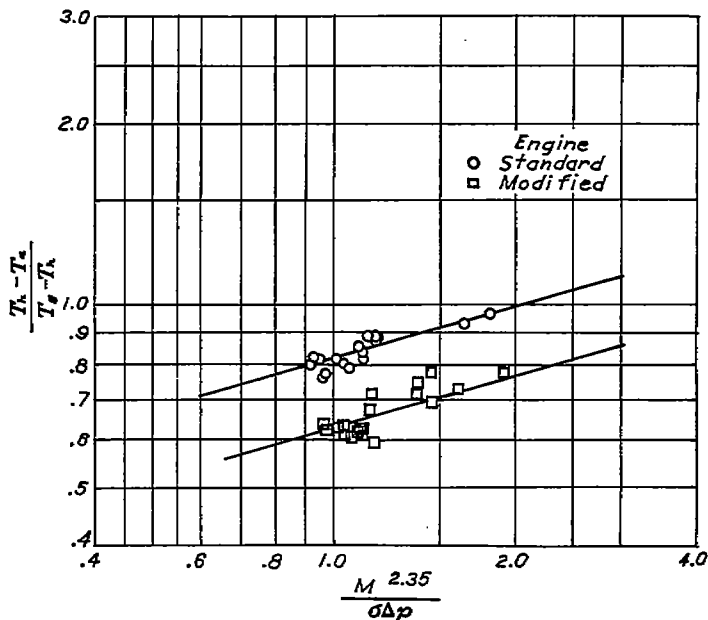

FIGURE 7.—Comparison between correlation of cooling data for standard and modified engines in port inboard nacelles of airplane, based on temperature of hottest rear-row exhaust-valve seat.

installation using the NACA injection impeller and ducted head baffles on all rear-row cylinders are shown in figure 7. The following relations between the maximum temperature of the rear-row exhaust-valve seat and the engine operating conditions were found to apply for the standard engine installation

$$\frac{T_h - T_a}{T_c - T_h} = 0.82 \frac{M^{0.66}}{(\sigma \Delta p)^{0.28}} \quad (6)$$

and for the modified engine installation incorporating the injection impeller and ducted head baffles

$$\frac{T_h - T_a}{T_c - T_h} = 0.63 \frac{M^{0.66}}{(\sigma \Delta p)^{0.28}} \quad (7)$$

The variation of the effective combustion-gas temperature with fuel-air ratio (reference 10) is shown in figure 8 at a carburetor-deck temperature of 0° F. Because the engine incorporates a geared supercharger, the effective gas temperature also depends on engine speed, and consequently curves are given for three engine speeds. The value of the effective gas temperature given by figure 8 must be increased by 0.80

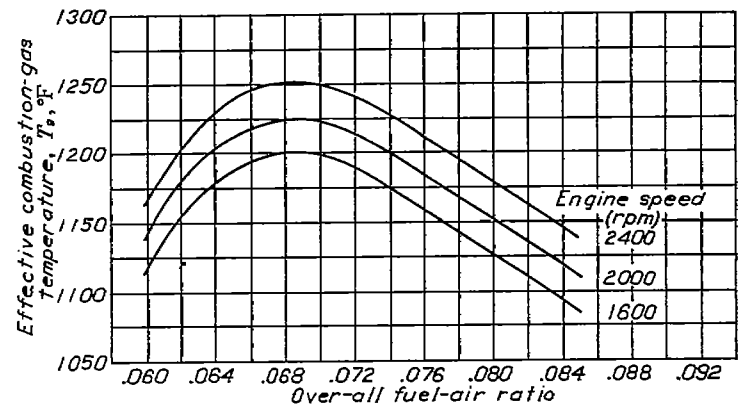

FIGURE 8.—Relation of effective combustion-gas temperature to over-all fuel-air ratio for standard engine. Carburetor-deck temperature, 0° F. (Data from reference 10.)

of the carburetor-deck temperature in degrees Fahrenheit when applying the curves.

Nondimensional form of results.—In order to present the results nondimensionally, a set of reference conditions that vary only with airplane weight was chosen for convenience. On the assumption that the turbosupercharger maintains sea-level back pressure at all times, the following reference conditions correspond closely to those providing the maximum specific range for a particular airplane weight if the engine temperature limit is disregarded:

1. Standard sea-level Army summer air: $\sigma=1.0$ and $\rho=0.00221$ slug per cubic foot
2. Cowl flaps at 2° (closed) position
3. Level flight at maximum lift-drag ratio
4. Minimum brake specific fuel consumption for required power

The power required for sea-level flight at maximum lift-drag ratio, and consequently the minimum brake specific fuel consumption (condition 4), varies only with airplane weight.

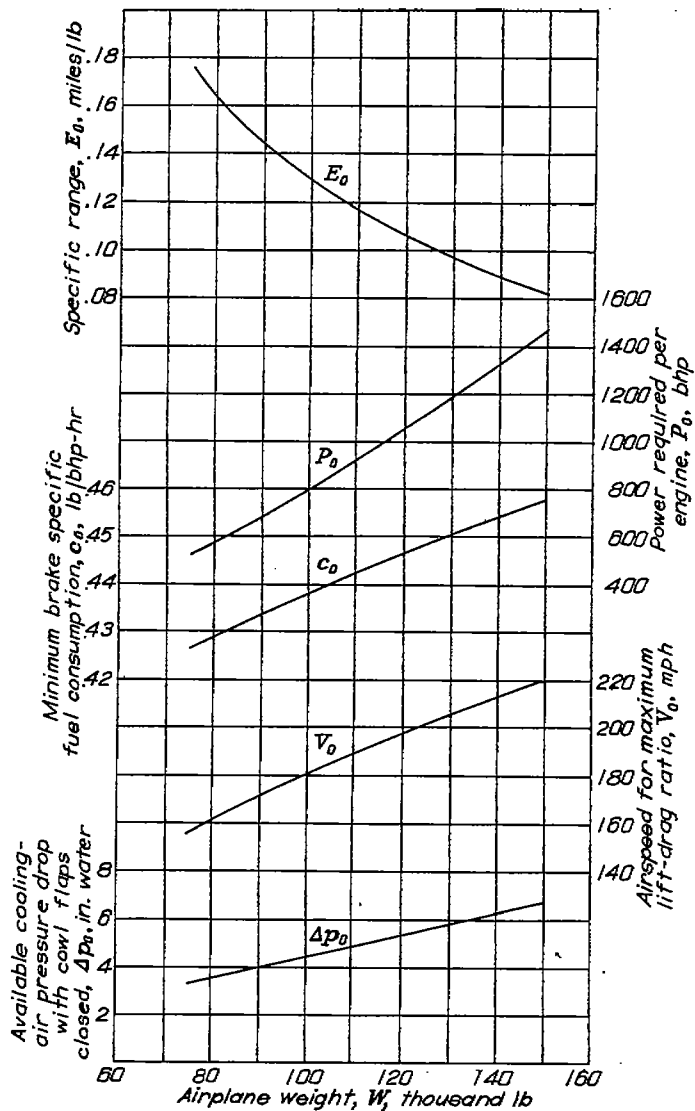

FIGURE 9.—Level-flight cruising conditions for various gross airplane weights. Standard sea-level Army summer air ($\sigma=1.0$ and $\rho=0.00221$ slug per cubic foot); cowl flaps at 2° (closed) position; level flight at maximum lift-drag ratio; minimum brake specific fuel consumption for required power.

The values of the airplane specific range and the values of the important associated variables are shown in figure 9 for the reference conditions over the complete range of airplane weights.

RESULTS AND DISCUSSION

In the presentation of the relation between the specific range and the airplane operating conditions as well as in the comparison of the airplane using the standard- and the modified-engine installations, the specific range has been expressed as a function of the brake specific fuel consumption and one of the three flight variables: airspeed, altitude, or gross airplane weight. These relations among the variables affecting the specific range of the airplane are represented by three-dimensional curves.

PERFORMANCE LIMITATIONS IMPOSED BY COOLING REQUIREMENTS AND ENGINE OPERATION

The nature of the performance limitations imposed by the engine performance and the cooling requirements may be understood through graphical solution (fig. 10) of the simultaneous equations characterizing cruising with proper engine cooling. For operation at a given altitude, airplane gross weight, and cowl-flap angle, the apparent power required is related to the indicated airspeed by equation (4) and the specific range may be found in terms of the indicated airspeed and the brake specific fuel consumption. This relation, plotted three-dimensionally in figure 10 (a), is terminated by the minimum attainable brake specific fuel consumption, as indicated by the hatched area. Inasmuch as the engine power is known, the engine speed, the fuel-air ratio, and the cooling-air pressure drop (figs. 1, 2, and 6, respectively) can be found for a given indicated airspeed and brake specific fuel consumption. This information is sufficient for calculating the temperature of the exhaust-valve seat according to equation (6) or equation (7) and consequently any point of the surface representing specific range at a given cowl-flap angle (fig. 10 (a)) has a definite cylinder-head temperature. Curves of constant head temperature can then be drawn on the surface, as shown in figure 10 (b). The maximum cylinder-temperature criterion prohibited safe engine operation in a certain area of the specific-range surface with the restriction most severe in the vicinity of the stoichiometric mixture where the maximum combustion-gas temperature occurs. The hatched area of figure 10 (b) must therefore be disregarded because of cooling difficulties. A similar situation exists for each cowl-flap opening; these other surfaces and their limiting temperatures lines are shown in figure 10 (c). The usable envelope of these surfaces (fig. 10 (d)) encompasses, for the assumed altitude and gross airplane weight, all cruising conditions possible with proper engine cooling. The surface representing the limiting specific range consists of three distinct parts: (1) normal specific-range surface with closed cowl flaps, continuing until limiting head temperature is reached; (2) the portion for which limiting head temperature exists for all cowl-flap angles; and (3) the normal cruising economy surface at full-open cowl flaps, continuing until limiting head temperatures are reached. Although excessive cooling is available at all points within this region, the most economical cruising conditions are represented by the upper portion of the surface and consequently only this part need be considered.

The operating altitude or the gross weight, as well as the airspeed, could be considered individually independent and similar surfaces would be obtained. Surfaces of this type are shown in figures 11 to 13 for the standard-engine installation. The extension of operation toward high speeds, altitudes, or gross weights will be eventually limited by engine power, whereas the limitation at rich mixtures (large brake

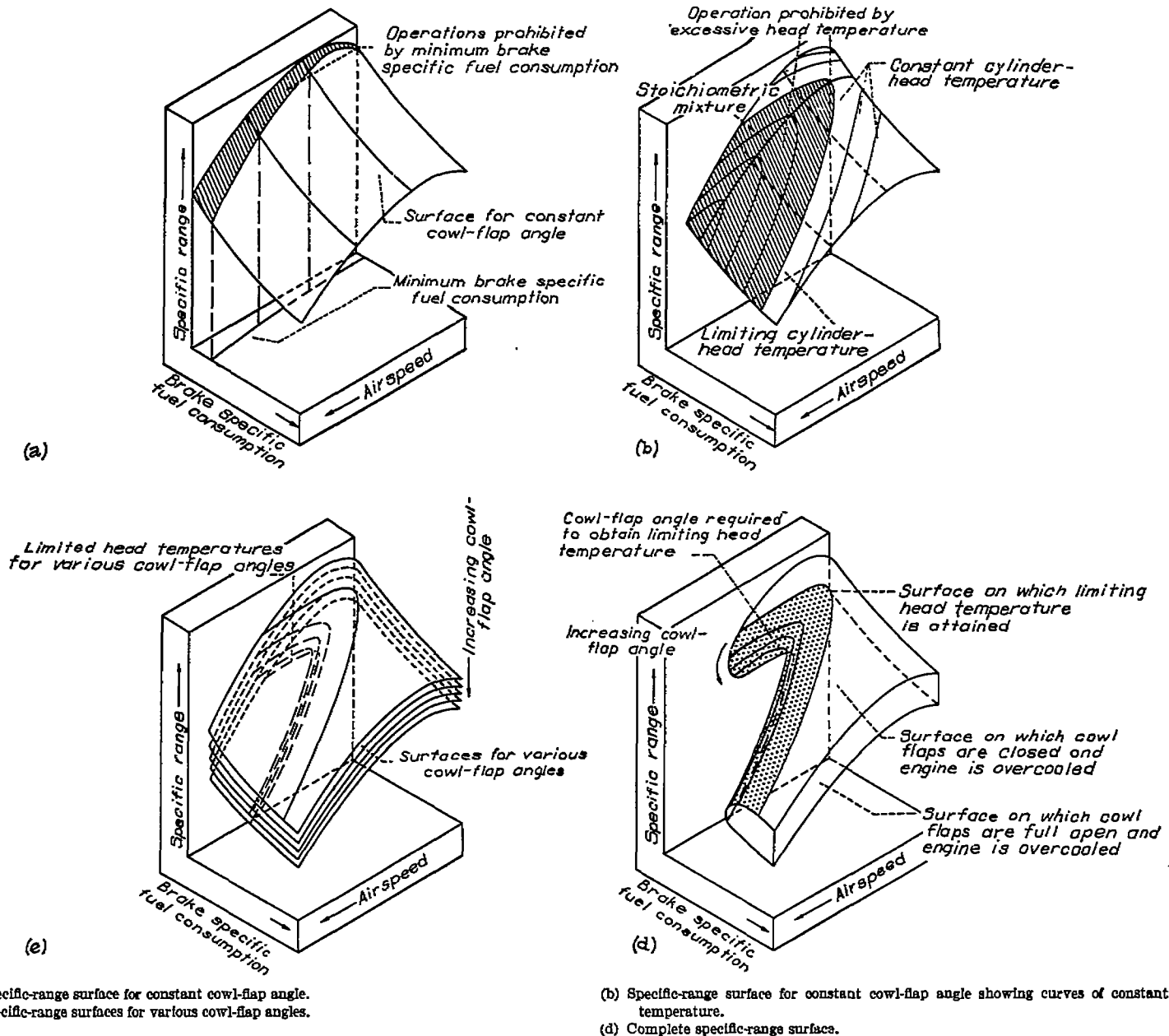

FIGURE 10.—Development of surfaces showing specific range with proper engine cooling as function of flight and engine variables.

specific fuel consumption) is very indefinite. Operation at very low speeds is aerodynamically unstable. Because these limitations are indefinite and of little importance herein, the figures are terminated arbitrarily at low speeds and rich mixtures.

For a given brake specific fuel consumption, the airspeed (fig. 11), the altitude (fig. 12), and the gross weight (fig. 13) are limited by the available cooling facilities. Cooling limitations of airplane performance are most severe near the stoichiometric mixture; that is, where the maximum

value of the combustion-gas temperature is encountered. Satisfactory engine cooling can usually be attained at enriched mixtures but can or cannot be attained at mixtures leaner than the stoichiometric, depending on the severity of the cooling requirements and on the mixture at which engine operation becomes unsatisfactory.

When a cooling limit exists, it can be physically observed by noting the response of specific range to the progressive leaning of a rich mixture at a given airplane speed. When the fuel-air ratio (or brake specific fuel consumption) is de-

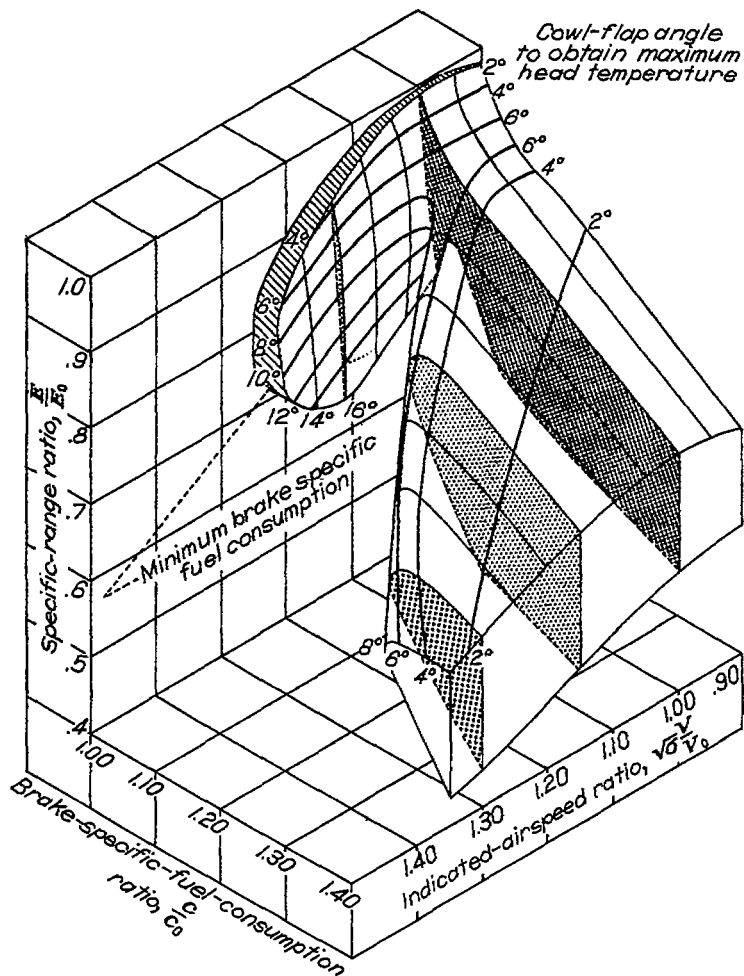

FIGURE 11.—Effect of airspeed and brake specific fuel consumption on specific range with cowl flaps set for proper engine cooling. Standard-engine installation; airplane weight, 100,000 pounds; altitude, 5000 feet.

creased, the cowl flaps must be opened to retain proper engine cooling. At some particular cowl-flap setting, depending on the indicated airspeed, a greater cowl-flap angle necessitates such a large increase in engine power that the cooling-air pressure drops required are greater than those available from the increased cowl-flap angle. An example of this cooling limit occurs in figure 11 at an indicated-air-speed ratio of 1.30. Continuous leaning of the mixture is therefore impossible and the additional cowl-flap opening has only decreased the specific range at the same mixture and airplane speed. Although successful airplane operation and engine cooling can be accomplished at cowl-flap angles greater than those occurring at the cooling-limited performance, increased fuel consumption and sacrifice in specific range results. Such conditions of operation are of no practical importance.

DETERMINATION OF MAXIMUM SPECIFIC RANGE

For a given airplane weight and operating altitude, it

appears from figure 11 that proper engine cooling may be attained at a variety of airspeeds, mixtures, and cowl-flap angles. The combination of these variables affording the most desirable cruising performance must be used as a guide to the proper flying conditions and to serve as a basis of comparison for the standard- and the modified-engine installations. The maximum specific range was considered the governing factor for level-flight conditions; however, in order to investigate the essential characteristics of the specific range at various airspeeds, determination of the maximum specific range is considered in two parts: (1) proper combination of cowl-flap angle and mixture strength, and (2) most economical airplane speed.

Optimum combination of cowl-flap angle and mixture strength.—The results of the analysis relating specific range and cooling requirements fall into two classes, differentiated by whether cooling is possible at mixtures leaner than the stoichiometric. The distinction is not concerned, however, with cooling at the stoichiometric mixture.

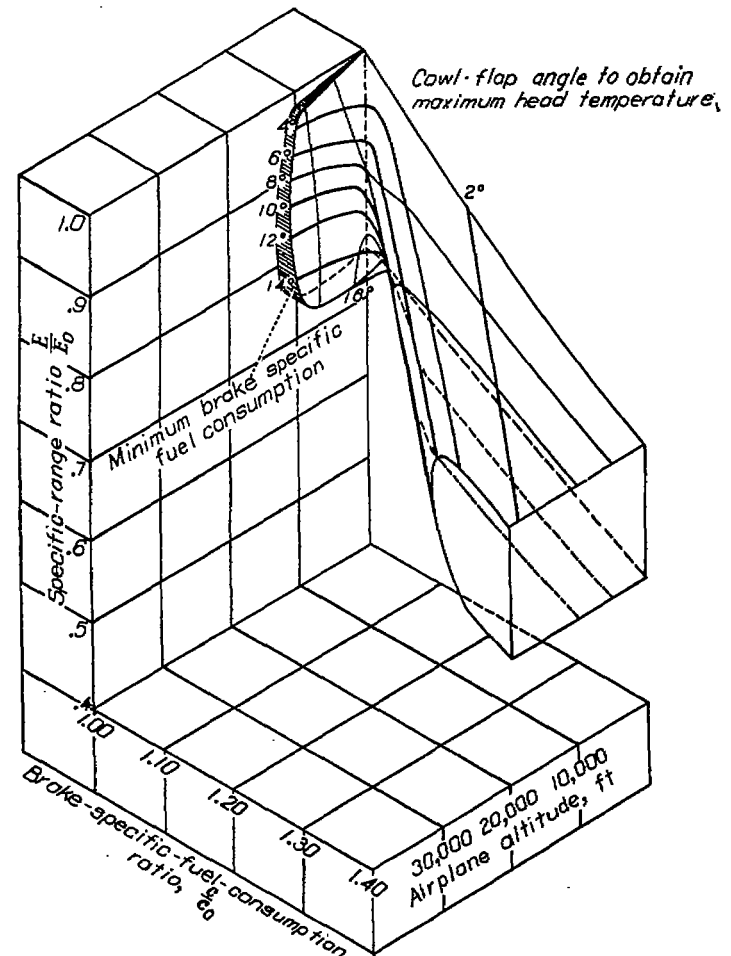

FIGURE 12.—Effect of airplane altitude and brake specific fuel consumption on specific range with cowl flaps set for proper engine cooling. Standard-engine installation; indicated-air-speed ratio, 1.00; airplane weight, 100,000 pounds.

Typical examples of the first case, where cooling is possible at mixtures leaner than the stoichiometric, are shown in figure 11 by the cross sections at indicated-air-speed ratios $\sqrt{\sigma} \frac{V}{V_0}$ of 1.00 and 1.15. Under these conditions, the greatest specific range for a given airspeed is always attainable at the minimum brake specific fuel consumption even though appreciable cowl-flap angles are required; the cowl-flap angle generally appears to be of less importance than the mixture strength. This result does not preclude the possibility of cooling improvements (such as changes in baffle configuration) that increase the specific range by decreasing the required cowl-flap angle for a given brake specific fuel consumption.

The second case in figure 11, section at $\sqrt{\sigma} \frac{V}{V_0} = 1.30$, concerns the optimum cruising conditions when proper engine cooling is impossible near, or leaner than, the stoichiometric mixture. Rich mixtures are essentially inefficient and can usually be avoided by reducing the airplane speed or altitude. When it is necessary to operate under circumstances requiring a rich mixture, both fuel-air ratio and cowl-flap angle must be considered because reducing the fuel-air ratio to the minimum value for which cooling is possible requires large cowl-flap angles and effects considerable loss in specific range. Although the maximum specific range occurs at widely different mixture strengths depending on the airplane speed, altitude, and weight, the cowl-flap angle for maximum specific range for rich-mixture operation is usually between 4° and 6° . Inasmuch as the specific range is insensitive to small changes in mixture strength in the neighborhood of the maximum value, setting the cowl flap at approximately 5° and leaning the mixture until the limiting head temperature is encountered appears to be a reasonable procedure for approximating the maximum specific range.

Indicated airspeed.—The airspeed leading to the maximum specific range for a given altitude and airplane weight will be investigated in two cases depending, like the optimum combination of cowl flap and mixture, on whether engine cooling is possible at mixtures leaner than stoichiometric.

If proper cooling is attained at mixtures leaner than stoichiometric, the maximum specific range is always (for a given airplane weight and altitude) achieved at the airplane speed providing the maximum lift-drag ratio. The maximum value of specific range shown in figure 11 is of this nature. Deviations of the conditions for specific range from the minimum brake specific fuel consumption and the maximum lift-drag ratio are small if the propulsive efficiency is assumed constant.

When satisfactory engine cooling is impossible at mixtures leaner than stoichiometric, the maximum specific range may occur either at the velocity giving the maximum lift-drag ratio and an enriched mixture or at an airplane speed (and engine power) sufficiently below that giving maximum lift-

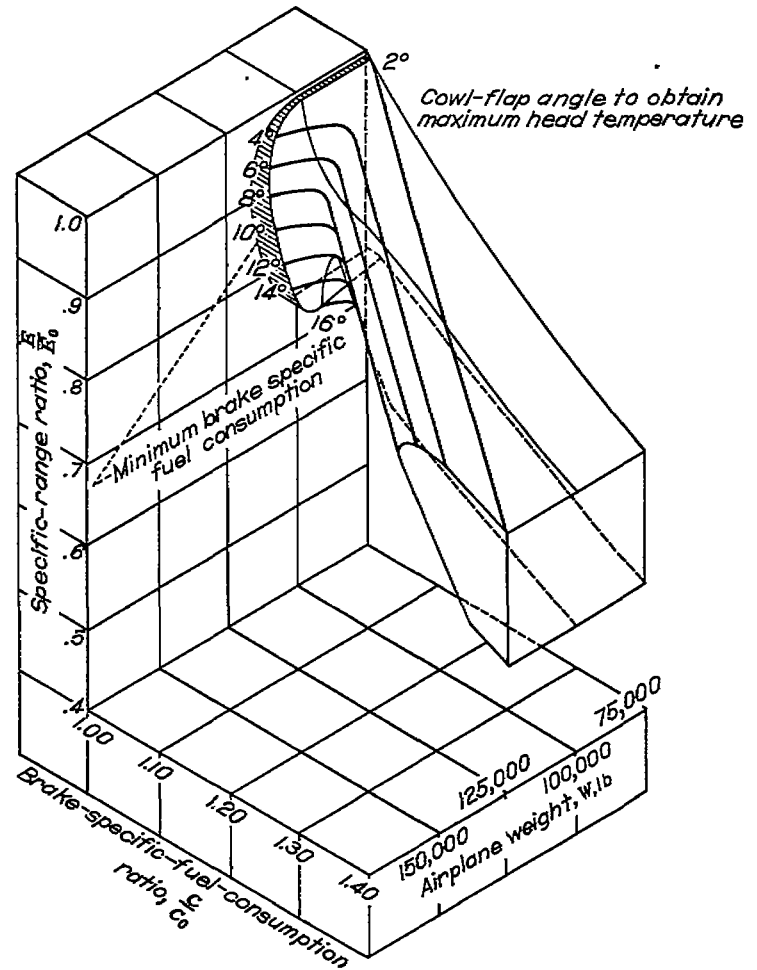

FIGURE 13.—Effect of airplane weight and brake specific fuel consumption on specific range with cowl flaps set for proper engine cooling. Standard-engine installation; indicated-air-speed ratio, 1.00; altitude, 5000 feet.

drag ratio to allow engine cooling in a lean condition. The reduction of airspeed below that giving maximum lift-drag ratio is generally prohibited by the tendency of the airplane to attain trim at either of the two airspeeds (fig. 5) corresponding to the given power. For comparison, it is assumed that airplane operation at maximum lift-drag ratio is satisfactory but that lower speeds are unsatisfactory. Consequently, under the foregoing assumption, the maximum specific range will be attained at the maximum lift-drag ratio and the optimum cowl-flap and mixture settings for both lean and rich operating mixtures.

PERFORMANCE WITH IMPROVED COOLING CHARACTERISTICS

The improvement in engine cooling characteristics resulting from use of the NACA injection impeller and ducted head baffles on the rear-row cylinders permitted a general increase in specific range because of the smaller cowl-flap angles and leaner mixtures required for proper cooling. The operating altitudes and the airplane weights for which proper

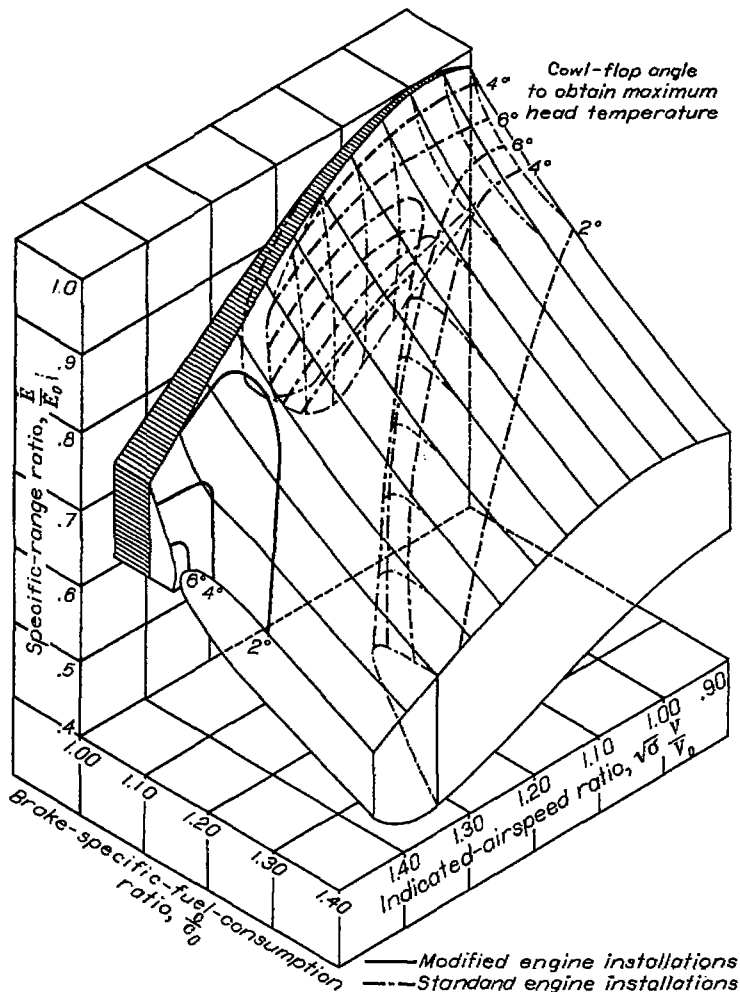

FIGURE 14.—Effects of airspeed and brake specific fuel consumption on specific range with standard- and with modified-engine installations. Cowl flaps set for proper cooling; airplane weight, 100,000 pounds; altitude, 5000 feet.

cooling is possible at lean mixtures were indicated to be greatly extended. Comparison of specific range for various airspeeds, operating altitudes, and weights are given in figures 14, 15, and 16, respectively.

Specific range and cruising range.—For operating conditions at which proper cooling was possible with small cowl-flap angles for the standard airplane, only small improvements in the specific range are shown for the modified airplane because the cowl-flap losses are quite small in this range. For conditions where the standard airplane required large cowl-flap angles, the improvement in the specific range is quite great, attaining its maximum value in the vicinity of the cooling-limited performance of the standard engine. The percentage improvement in specific range resulting from the use of the NACA injection impeller and ducted head baffles is summarized for various airspeeds, altitudes, and airplane weights in the following table:

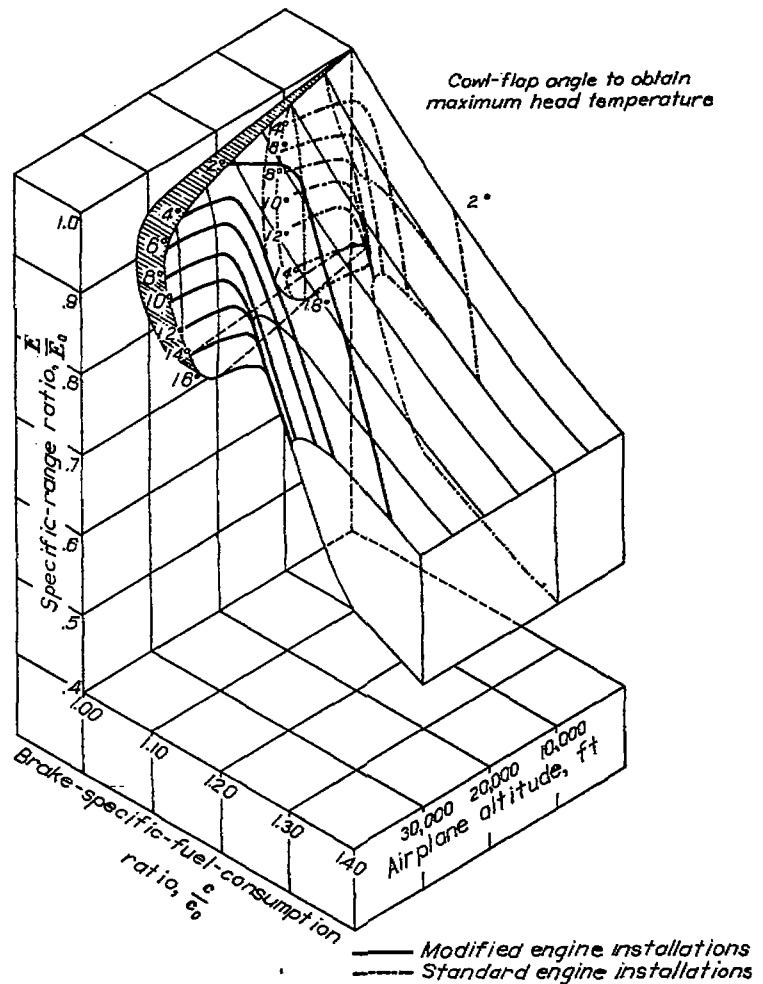

FIGURE 15.—Effects of airplane altitude and brake specific fuel consumption on specific range with standard- and with modified-engine installations. Cowl flaps set for proper engine cooling; indicated-air-speed ratio, 1.00; airplane weight, 100,000 pounds.

Gross weight (lb)	Sea level			10,000			20,000		
	1.00	1.20	1.40	1.00	1.20	1.40	1.00	1.20	1.40
75,000	0	0	1.5	0	0	3.7	0	19.8	25.8
100,000	0	2.4	31.0	17.8	28.4	(*)	35.4	(*)	(*)
125,000	23.2	38.1	(*)	(*)	(*)	(*)	(*)	(*)	(*)

* Impossible to maintain valve-seat temperature below 500° F with standard-engine installation.

The maximum specific range of the installation with the standard and the modified engine was determined for wide ranges of airplane weights and operating altitudes. Inasmuch as the maximum specific range is a function of only two variables, the maximum specific range for the standard-

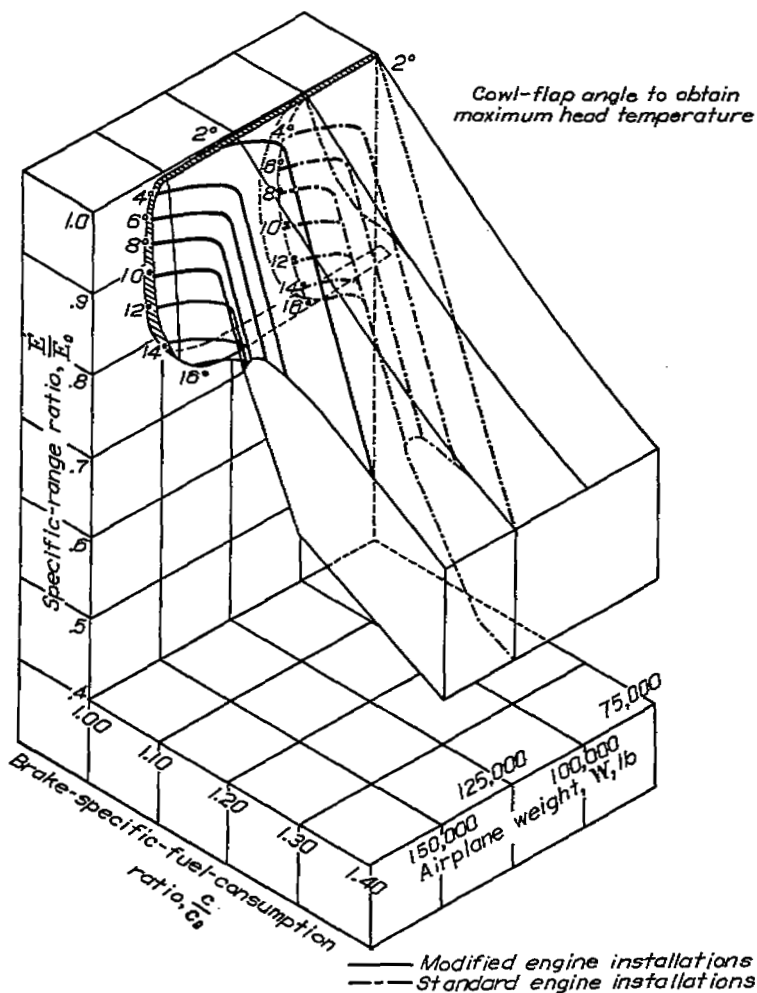

FIGURE 16.—Effects of airplane weight and brake specific fuel consumption on specific range with standard- and with modified-engine installations. Cowl flaps set for proper engine cooling; indicated-air-speed ratio, 1.00; altitude, 8000 feet.

and the modified-engine installations has been plotted in figure 17 against airplane weight for various altitudes. The discontinuities that occur at certain altitudes are caused by the transition from lean to rich mixtures when lean operation becomes impossible.

The curves of figure 17 have a simple and useful interpretation in terms of the level-flight cruising range of the airplane. In accordance with equation (2), the airplane range may be expressed as

$$R = \int_{W_s}^{W_s + W_f} E(\sigma, W) dW \quad (8)$$

where $E(\sigma, W)$ is the specific range available for an airplane of weight W and flying at an altitude corresponding to the density ratio σ . The limits of the integral indicate that the integration extends from the weight of the airplane with fuel to the weight of the airplane with all fuel expended. For a given altitude, the value of this integral corresponds to the area under the curve (fig. 17) for the appropriate altitude

taken between abscissa values of W_s and $W_s + W_f$. During the flight, values of the instantaneous specific range increase as the total weight of the airplane decreases. The calculation of the level-flight cruising range is therefore a simple matter for any particular set of conditions. Values of the airplane range computed in this manner are approximate and do not account for the fuel expended in take-off, climb, and level flight at conditions other than optimum.

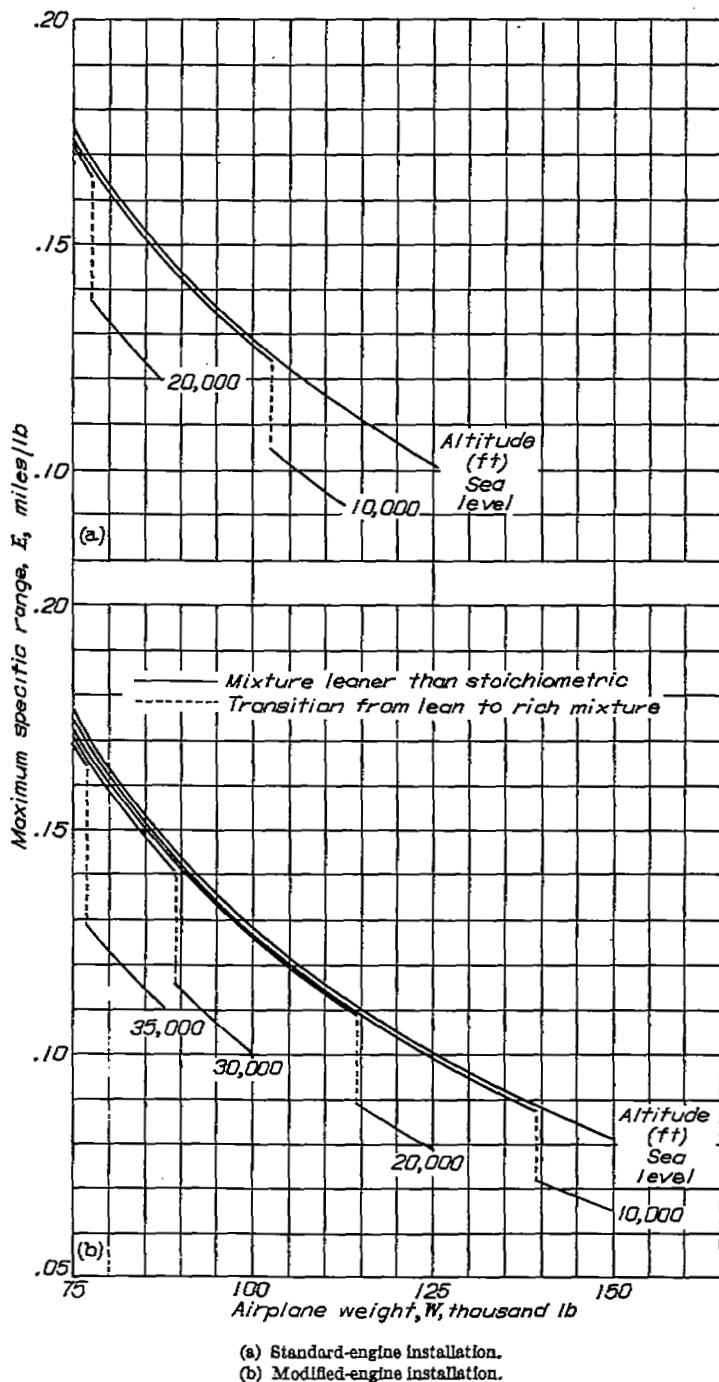

FIGURE 17.—Variation of maximum specific range with gross weight for airplane at several altitudes.

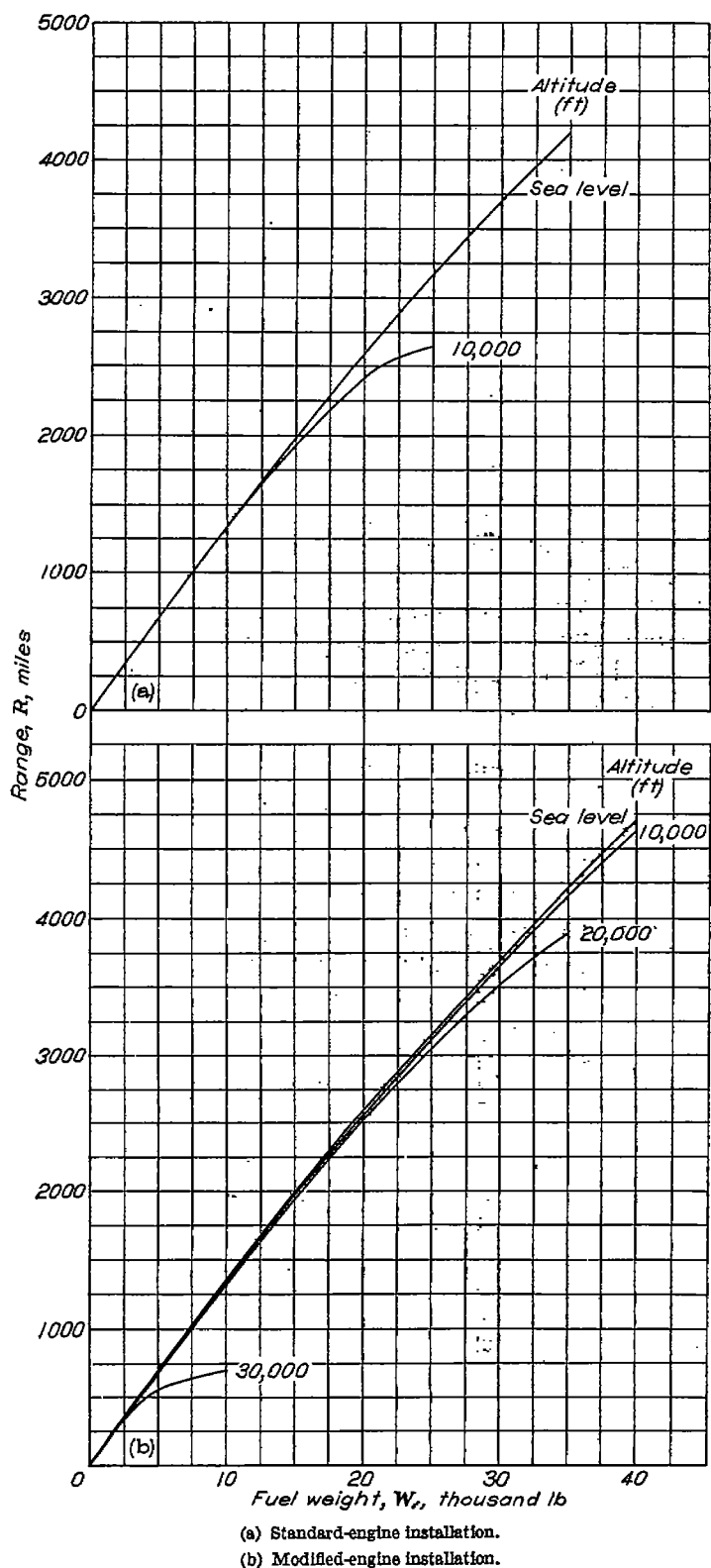

FIGURE 18.—Effect of improved cooling performance on estimated cruising range at several altitudes; theoretical estimates based on maximum calculated specific range for both installations. Army summer air conditions; airplane weight less fuel weight, 90,000 pounds.

Calculations of level-flight cruising range for a basic airplane weight of 90,000 pounds (airplane gross weight less fuel weight) made for various fuel weights and altitudes are presented in figure 18. The results of the calculations indicate that improvement as great as 17 percent in the cruising range of the airplane may be achieved by the use of the NACA injection impeller and the ducted head baffles and

that the greatest improvement in range results from the possibility of using lean instead of rich mixtures.

Extension of operating conditions.—In general, the airspeed at which the specific range was optimum was unaffected by the cooling improvements. The values of airspeed for which cooling of the hottest rear-row exhaust-valve seat is possible have, however, been greatly extended. (See fig. 14.) The operating altitudes and the airplane weights that may be used without exceeding the arbitrarily chosen limiting temperature for the rear-row exhaust-valve seats of 560°F have been markedly increased (figs. 15 and 16). This improvement is shown more clearly in figure 17 where the approximate limiting altitude of operation for various values of airplane weight may be observed for both the standard- and the modified-engine installation. Limits are shown for operation at conditions both richer and leaner than the stoichiometric mixture.

The use of the injection impeller and ducted head baffles permits, for both lean and rich mixtures (fig. 17), an increase of operating altitude in excess of 10,000 feet for all airplane gross weights considered. It is also evident that rich-mixture operation permits an additional altitude increase of less than 5000 feet above that possible with lean-mixture operation. This increase is accompanied by a considerable loss in specific range.

The improved cooling facilities may also be evaluated in terms of the additional gross weight allowable at a given altitude without exceeding the limits set on the rear-row exhaust-valve-seat temperature. For any altitude between 10,000 and 25,000 feet, the cooling improvements permit a gross-weight increase of at least 35,000 pounds from that available with the standard-engine installation (fig. 18). Below an altitude of 10,000 feet, the allowable increase in gross weight is reduced to as low as 10,000 pounds by engine power limitations.

SUMMARY OF RESULTS

Flight tests of a four-engine heavy bomber using the standard-engine installations and the installation modified by the injection impeller and ducted head baffles have been analyzed to determine the theoretical improvement of airplane performance that can be achieved through improving the cooling characteristics of the engine installation. The analysis was extended to determine the limitations imposed by the original cooling difficulties and the operating conditions that would minimize their effect and take maximum advantage of the cooling improvements. Approximations were made concerning the variation of minimum brake specific fuel consumption with engine speed and the value of fuel-air ratio at which the minimum brake specific fuel consumption occurs. The variation of propulsive efficiency was neglected. The theoretical results of the analysis for an assumed limiting temperature of 560°F on the rear-row exhaust-valve seat and standard Army summer air conditions are as follows:

1. When proper cooling was possible at mixtures leaner than stoichiometric, the best specific range for a given airspeed was achieved by using the minimum brake specific fuel consumption and any cowl-flap angle required to cool the engine properly.

2. When proper cooling was impossible at mixtures leaner than stoichiometric, the best specific range for a given airspeed was achieved by using a cowl-flap angle of approximately 5° open and the leanest mixture that allows proper cooling.

3. The maximum airplane specific range (and, consequently, the maximum cruising range) was always attained with the appropriate mixture-cowl flap combination and an airspeed corresponding to the maximum lift-drag ratio, if the airplane flying altitude was stable at this point.

4. For flying conditions at which the specific range of the standard airplane is seriously reduced by large cooling requirements, engine-installation analysis indicated that the specific range was, in an extreme case, increased as much as 38 percent through use of engines employing the injection impeller and ducted head baffles.

5. Analysis of flight-test data indicated that improvement in engine cooling performance through use of the NACA injection impeller and ducted head baffles allowed an increase in operating altitude in excess of 10,000 feet or a gross-weight increase of from 10,000 pounds at sea level to at least 35,000 pounds above 10,000 feet without exceeding an exhaust-valve-seat temperature of 560° F.

AIRCRAFT ENGINE RESEARCH LABORATORY,
NATIONAL ADVISORY COMMITTEE FOR AERONAUTICS,
CLEVELAND, OHIO, *March 14, 1946.*

REFERENCES

1. Marble, Frank E., Ritter, William K., and Miller, Mahlon A.: Effect of NACA Injection Impeller on Mixture Distribution of Double-Row Radial Aircraft Engine. NACA Rep. No. 821, 1945.
2. Sipko, Michael A., Cotton, Charles B., and Lusk, James B.: Use of Ducted Head Baffles to Reduce Rear-Row Cylinder Temperatures of an Air-Cooled Aircraft Engine. NACA TN No. 1053, 1946.
3. Marble, Frank E., Miller, Mahlon A., and Vensel, Joseph R.: Effect of NACA Injection Impeller and Ducted Head Baffles on Flight Cooling Performance of Double-Row Radial Engine in Four-Engine Heavy Bomber. NACA MR No. E5D13, Army Air Forces, 1945.
4. Kerber, L. V.: Induced Drag and Equivalent Monoplane Aspect Ratio. Vol. V of Aerodynamic Theory, div. O, ch. II, sec. 3, W. F. Durand, ed., Julius Springer (Berlin), 1935, pp. 230-232.
5. Reed, Albert C.: Airplane Performance Testing at Altitude. Jour. Aero. Sci., vol. 8, no. 4, Feb. 1941, pp. 135-150.
6. Allen, Edmund T.: Flight Testing for Performance and Stability. Jour. Aero. Sci., vol. 10, no. 1, Jan. 1943, pp. 1-24; discussion, pp. 25-30.
7. Wyatt, DeMarquis D., and Conrad, E. William: An Investigation of Cowl-Flap and Cowl-Outlet Designs for the B-29 Power-Plant Installation. NACA MR No. E5K30a, Army Air Forces, 1946.
8. Katzoff, S., and Finn, Robert S.: Determination of Jet-Boundary Corrections to Cowling-Flap-Outlet Pressures by an Electrical Analogy Method. NACA ARR No. 4B23, 1944.
9. Pinkel, Benjamin: Heat-Transfer Processes in Air-Cooled Engine Cylinders. NACA Rep. No. 612, 1938.
10. Pinkel, Benjamin, and Rubert, Kennedy F.: Correlation of Wright Aeronautical Corporation Cooling Data on the R-3350-14 Intermediate Engine and Comparison with Data from the Langley 16-Foot High-Speed Tunnel. NACA ACR No. E5A18, 1945.